

Transition Roadmap for Developing District Heating in South Dublin



Researched by	Checked by	Reviewed by	First Draft	Final Draft
John O'Shea	Donna Gartland	Donna Gartland Catherine Fitzgerald	January 2019	May 2019

Author(s): John O'Shea, Codema
Donna Gartland, Codema
Joe Hayden, Codema

Email: john.oshea@codema.ie
Phone: +353 (0)1 707 9818
Address: The Loft, 2-4 Crown Alley, Temple Bar, Dublin 2

Deliverable: WP.LT D1.3 Transition Roadmap

Date: May 2019

About HeatNet NWE

This document has been developed as part of the HeatNet NWE project, which is part-funded through the Interreg NWE programme and aims to increase the uptake of 4DHC networks across North-West Europe. As part of this project, the partners are developing the HeatNet Model, which will help the public sector to begin implementing 4DHC networks, and the Transition Roadmaps, which will outline the partners' experience in developing six district heating pilots across North-West Europe. The HeatNet Guide to Financing is also currently being developed and will give a broad overview of the various sources available to finance district heating schemes.

For further information on these reports and on the HeatNet NWE project, please visit www.guidetodistrictheating.eu.

Copyright © 2019 Codema

All rights reserved

Reproduction of the contents of this report are permissible provided the source is acknowledged.

Disclaimer

While the authors consider that the information given in this work is sound, all parties must rely upon their own skill and judgment when making use of it. The authors do not make any representation or warranty, expressed or implied, as to the accuracy or completeness of the information contained in this report and assumes no responsibility for the accuracy or completeness of such information. The authors will not assume any liability to anyone for any loss or damage arising out of the provision of this report.

Table of Contents

Table of Tables.....	8
Table of Figures	8
Executive Summary	10
The Carbon Reduction and Renewable Heating Potential of District Heating	10
Purpose of the Transition Roadmap	10
Summary of Findings	11
Heat Source Analysis and Mapping	11
Heat Source Breakdown	11
Opportunity Areas Identified.....	12
Steps in the Transition	12
Next Steps.....	13
1. Introduction.....	15
1.1 What is District Heating	15
1.2 Interreg NWE HeatNet Project Background.....	16
1.3 The Purpose of this Document.....	17
1.4 How to Use this Document	19
1.5 The South Dublin District Heating Pilot Project – Tallaght District Heating Scheme	20
1.6 Support from Senior Council Members	21
2. Supporting Legislation & Policy Context.....	22
2.1 EU Level Policy Context.....	22
2.2 National Level Policy Context.....	22
2.3 South Dublin Policy Context.....	25
3. Planning Policy for District Heating	28
3.1 Current DH Planning Policy Adopted by SDCC	28
Waste Heat Utilisation Wording in Forward Planning Report Appraisal	28
District Heating Planning Policy – Policy 6.....	30
3.2 Policy Options Adopted in Other Regions	31
London – The New London Plan	31
Amsterdam	33
Scotland	33
progRESsHEAT Project Countries (Denmark, Germany, Portugal, Czech Republic, Austria, Romania) Policy Recommendations.....	33
3.3 Forward Planning & Future-proofing	34
4. Energy Master-Planning: Identifying District Heating Opportunity Areas.....	35
4.1 Heat Demand	35

4.2	Heat Sources	38
	Heat Sources Summary	38
	Heat Source Breakdown	40
	Heat Source Descriptions	41
4.3	Physical/Spatial Constraints	45
1.4	Opportunity Areas Identified	45
	Identification Methodology	45
	Opportunity Areas Ranked Based on High-level Assessment	46
5.	Techno-Economic Analysis	50
5.1	The Importance of Performing a Techno-Economic Analysis	50
5.2	Example Techno-Economic Analysis: Tallaght District Heating Scheme	51
6.	Stakeholder Engagement – Who to Involve in Your DH Project and When	55
6.1	Introduction to Stakeholder Engagement	55
6.2	Effective Stakeholder Engagement	55
1.	Identifying the Relevant Stakeholders	55
2.	Understanding Stakeholder Drivers and Barriers	56
3.	Prioritise stakeholders	58
4.	Effective Engagement	60
	When to Involve the Relevant Stakeholders	61
7.	Information to be Provided to Developers	63
7.1	Benefits of District Heating	63
7.2	Trench Sizes Required for DH Network	63
7.3	Wayleave Requirements for DH Network	64
7.4	Allowable Distances Between DH Pipes and Other Services	64
7.5	The Importance of Secondary-Side Pipework Heat Losses	65
7.6	Maintenance Access Requirements	66
7.7	Provisions to be Made for Connection to DH Network – Developments within Opportunity Areas..	67
7.8	Contract for the Supply of Heat and Heads of Terms	67
7.9	Developer Contribution / Cost of Connection	68
7.10	What Disruption to Existing Buildings Could be Caused if Connecting to DH?	68
7.11	Retrofitting Older Buildings for Connection to 4 th Generation District Heating	68
8.	Planning Permission Requirements for Installing a Local Authority-Led District Heating System	69
8.1	Current Planning Requirements	69
8.2	Example Planning: Tallaght District Heating Scheme Planning Permission (Part 8)	69
9.	Business Model Options Available for a Local Authority-Led DH System	70
9.1	Choosing a Business Model	70

9.2	Business Model Options	70
9.3	Example Business Model: Tallaght District Heating Scheme Preferred Business Model	72
10.	Procurement and Contracting	76
10.1	Introduction to Procurement	76
10.2	Procurement Options for SDCC.....	76
10.3	Example of Procurement Evaluation: Tallaght District Heating Scheme	80
	Possible Procurement Options	80
	Procurement Route Chosen for South Dublin Pilot	80
10.4	Example Heat Supply Contract: Proposed Tallaght District Heating Scheme Contract – Local Energy Supply Contract	81
11.	Transition Roadmap	83
11.1	Actions for Delivering the Transition	83
11.2	Next Steps	85
	Appendix A: Transition Roadmap Actions	86
	Appendix B: Heat Source Map	90
	Appendix C: Heat Source Assessment Methodology.....	91
	Appendix D: Heat Source Temperatures & Collection Methods	98

A special thanks to those who provided information for the development of the heat source and physical constraints maps. These contributors are listed alphabetically below:

Alan Foley	Veolia
Anthony McNamara	South Dublin County Council
Blaithín Keegan	South Dublin County Council
Brendan Marren	CES Energy
Brian Montayne	ESB eHeat
Ciaran McCausland	Celtic Anglican Water
David McAuley	BitPower
Declan Ryan	Temp Technology
Dermot Dorgan	ESB Networks
James McAteer	Gavin & Doherty Geosolutions
James Nolan	Energy Engineered Solutions
Niall McKiernan	Fingal County Council
Paul Hennelly	Office of Public Works - Hydrometric Section
Sarah Blake	Geological Survey Ireland
Stephen Walsh	Geological Survey Ireland
Therese Pender	South Dublin County Council
Trevor McGarr	Swords WWTW

Table of Tables

Table 1: Opportunity Area Rankings.....	12
Table 2: Transition Roadmap Actions Timeline	13
Table 3: Land Use Abbreviation Description	37
Table 4: Description of Heat Sources Investigated.....	42
Table 5: Opportunity Area Rankings & Reasoning.....	47
Table 6: Pros & Cons of Low vs Medium/High Temperature District Heating System	52
Table 7: Drivers for the Development of District Heating - Examples	57
Table 8: Possible Information that could be Requested from Stakeholders	61
Table 9: Allowable Distances Between DH Pipes and Other Utilities	65
Table 10: Internal Pipework Insulation Requirements - Best Practice (Source: Connecting to the Bristol Heat Network Part 2, Energy Service, Bristol City Council 2018).....	66
Table 11: Risk & Control Allocation Table, Source: Delivery Structure Risk Allocation and Roles (IEA Annex XI Final Report 2017).....	70
Table 12: Procurement Procedures Available under S.I. 286 Award of Contracts by Public Authorities	77
Table 13: Procurement Procedures Available under SI 286 Award of Contracts by Utilities	78
Table 14: Transition Roadmap Concise Actions Table	83
Table 15: Heat Source Capacity Assessment Methodology.....	91
Table 16: Indicative Source Temperatures & Heat Collection Methods	98

Table of Figures

Figure 1: SDCC's Emissions 2009 - 2017, with Projected Glide Path to the 40% Reduction Target by 2030	10
Figure 2: Ireland's Progress Towards 2020 Renewables Targets.....	10
Figure 3: Heat Source Map	11
Figure 4: Number of Heat Source Sites Identified - Grouped by Type	12
Figure 5: Heat Source Capacity Breakdown (MW)	12
Figure 6: Opportunity Areas Identified.....	12
Figure 7: Indicative Diagram of a District Heating System (Source: REHAU).....	15
Figure 8: Potential Benefits of District Heating for SDCC (Source: Developing District Heating in North-West Europe: A Guide for Public Sector Organisations, Codema (2019).....	17
Figure 9: Proposed TDHS Energy Centre Elevation Drawing	20
Figure 10: 4DHC Transition Support Structure	21
Figure 11: Fuel Sources and Emissions in Swedish District Heating Systems (Source: Nordic Heating & Cooling 2017).....	23
Figure 12: Ireland's Energy Demand and Sources, with Heating Sector highlighted (Source: SEAI)	24
Figure 13: SDCC's Emissions 2009 - 2017, with Projected Glide Path to the 40% Reduction Target by 2030 (Source: South Dublin County Council Draft Climate Change Action Plan, Codema (2019)	26
Figure 14: South Dublin County Council Emissions per Category.....	27
Figure 15: Overview of progRESsHEAT Policy Recommendations.....	34
Figure 16: South Dublin Spatial Energy Demand Analysis Map.....	36
Figure 17: SDCC Land Use Zones	37
Figure 18: Combined Heat Source, Heat Demand and Relevant Development Zone (RES-N, REGEN & SDZ) Map	38
Figure 19: South Dublin Heat Source Map	40
Figure 20: Heat Sources Identified by Capacity (MW).....	41

Figure 21: Number of Heat Sources Sites Identified - Grouped by Type	41
Figure 22: South Dublin Constraints Map	45
Figure 23: Opportunity Areas Identified - Based on SEDA Heat Demand (>150 TJ/km ²), Relevant Land Use (SDZ, REGEN & RES-N) and Heat Source Locations	46
Figure 24: Hourly Plant Operation Profile from Energy Model - Example	50
Figure 25: Resulting Preferred Network Route	53
Figure 26: Example of Plant Size Modelling – Heat Production & Duration Curve	54
Figure 27: Stakeholder Main Objectives Overview - Sample Radar Chart	58
Figure 28: Specific Stakeholder Objectives - Sample Radar Chart	58
Figure 29: Indicative Impact - Interest Grid	59
Figure 30: Stakeholder Input Graph (source: CIBSE Heat Networks Code of Practice)	62
Figure 31: Stakeholder Involvement at Project Stage Graph, Source: BEIS Heat Network Detailed Project Development Resource: Guidance on Strategic and Commercial Case (2016)	62
Figure 32: Indicative Trench Dimensions (source: Logstor Design Manual)	64
Figure 33: Shared Riser Diagram (Source: CIBSE Heat Networks Code of Practice)	66
Figure 34: Business Model Strengths & Weaknesses for both Public and Public / Private Business Models (Source: HeatNet NWE Guide for Public Sector Organisations)	71
Figure 35: Business Model Canvas Template	73
Figure 36: Competitive Dialogue Procurement Timeline	81

Executive Summary

The Carbon Reduction and Renewable Heating Potential of District Heating

District heating is technology agnostic and has the inherent flexibility to utilise multiple diverse, locally available, renewable and low-carbon heat sources. District heating networks supplied by the local, low-carbon sources identified in the Heat Source Map have the potential to reduce carbon emissions in South Dublin by up to 250,000 tonnes of CO₂ per annum.

District heating can make a significant contribution to South Dublin County Council's (SDCC's) emissions reduction target for 2030 of 40% and is currently 3,270 tonnes of CO₂ away from this target¹, as shown in Figure 2. District heating will have a direct impact on the emissions of SDCC buildings (which represent 42% of SDCC's total emissions) connected to a low-carbon district heating network but also represents a huge opportunity in terms of carbon offsetting within the County based on this 250,000 tCO₂ figure, while also supplying low-cost heat to businesses and residents.

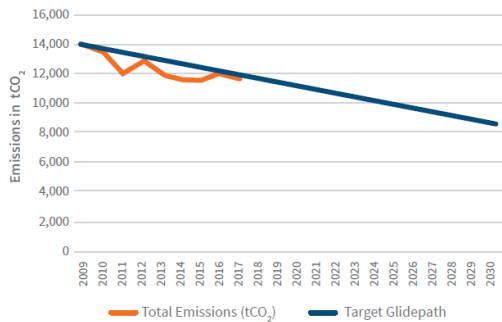

Figure 1: SDCC's Emissions 2009 - 2017, with Projected Glide Path to the 40% Reduction Target by 2030

In cases where heat pumps are used, this also contributes to Ireland's renewable heat target of 12% by 2020. This renewable heat (RES-H) proportion currently sits at 6.9%, which is only 58%

towards its target as shown in Figure 3 below, lagging behind the renewable contributions in both electricity (RES-E) and transport (RES-T).

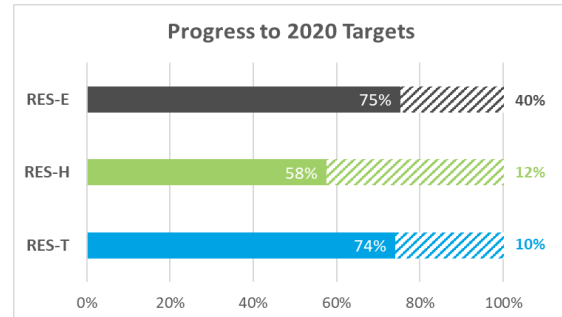

Figure 2: Ireland's Progress Towards 2020 Renewables Targets

Purpose of the Transition Roadmap

The objective of the Transition Roadmap is to help decarbonise the heating sector in South Dublin through the adoption of 4th generation district heating principles, e.g. utilising local, low-carbon heat sources such as industrial waste heat, and help SDCC achieve its CO₂ and energy efficiency targets:

- A 33% improvement in energy efficiency by 2020
- A 40% reduction in CO₂ by 2030

The roadmap suggests actions to be taken in the short, medium and long-term to catalyse and promote the development of district heating (DH) networks in the County, as discussed in section 11.1 of this report. Some of these actions have already been taken as part of this report, and are set out below:

- Develop a heat source map
- Identify opportunity areas with South Dublin using the combined heat source, heat demand and physical constraint maps
- Create a prioritised list of opportunity areas to create a pipeline of possible

¹ Based on 2017 CO₂ emission levels

projects to undergo more in-depth feasibility analysis

This report also provides high-level guidance in the following areas:

- How to effectively engage with stakeholders
- Information that can be provided to developers regarding DH
- Policy options that could be considered to support the roll-out of DH networks
- Business model options
- Procurement
- Emphasising the importance of good quality techno-economic analysis

Summary of Findings

The total heat demand in South Dublin is 2,700 gigawatt hours (GWh) per annum, based on a previous spatial energy demand analysis performed by Codema. The heat sources identified in the Heat Source Map have an estimated heating potential of 4,000 GWh per annum; this is approximately 50% greater than the total heat demand in South Dublin.

The heat demand in South Dublin located in areas suitable for connection to a DH system (i.e. areas with a heat density >150 TJ/km²) totals 1,240 GWh per annum. If this was supplied by the same mix of sources identified in the heat source map this would represent a reduction of approximately 250,000 tonnes of CO₂ per annum, when compared with the use of gas-fired boilers, which is assumed as the “business as usual” heat production method.

Eight opportunity areas have been identified, which warrant more detailed investigation into their viability for the adoption of DH. It is recommended that these investigations take the form of techno-economic feasibility studies for each of these areas.

Heat Source Analysis and Mapping

Codema investigated the potential of 18 different types of local, low-carbon heat sources within the South Dublin region using data from approximately

70 different sources. The heat sources investigated can be broken down into three main categories: commercial (e.g. process heat recovery, CHP excess heat and commercial cooling systems), infrastructural (e.g. power plants, landfill, waste water treatment and sewer heat), and environmental (e.g. surface water, deep geothermal). The heat sources can be seen in the map below and are described and shown in greater detail in Section 4.2.

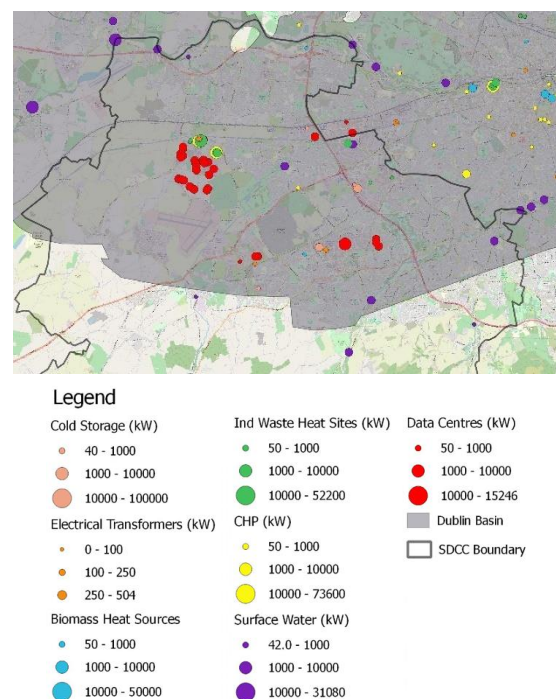

Figure 3: Heat Source Map

This investigation resulted in the identification of 115 individual heat sources within the South Dublin region, which give a total combined heat capacity of almost 500 megawatts (MW).

Heat Source Breakdown

The most common heat source identified was data centre waste heat, for which 38 sites were found. The next most common sources were potential deep geothermal doublet sites (28), surface water (17), industrial waste heat (10), combined heat and power (CHP) excess heat (9), cold storage facility waste heat (6), electrical transformer substations (5), and biomass boiler excess heat (2). This breakdown is shown in the figure below.

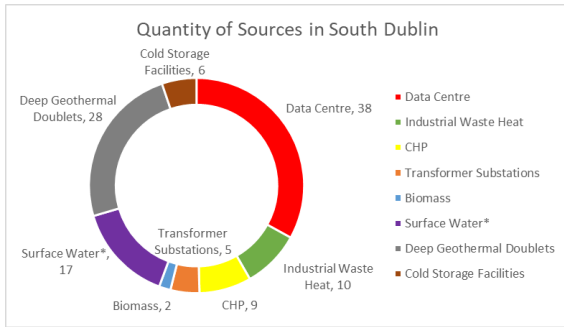

Figure 4: Number of Heat Source Sites Identified - Grouped by Type

Figure 6 below gives the breakdown of the heat sources identified by capacity. The methodology used in calculating these figures is discussed in greater detail in Appendix D. The Asterisk next to the surface water heat source indicates that this estimate is quite conservative and could be in excess of ten times this figure if different assumptions were made.

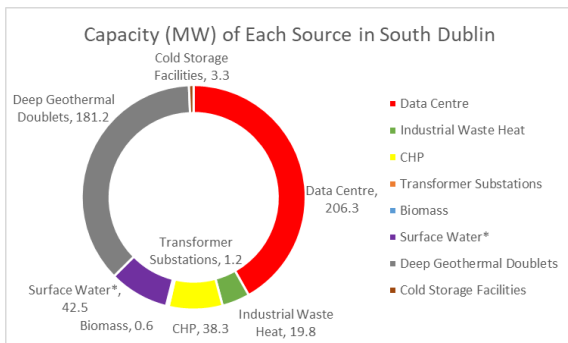

Figure 5: Heat Source Capacity Breakdown (MW)

Opportunity Areas Identified

Codema generated a map showing high heat density (of greater than 150 TJ/km²), regeneration (REGEN) zones, new residential (RES-N) zones, strategic development zones (SDZs) and the identified heat sources. This was used to highlight opportunity areas that warrant further investigation into their suitability for adopting district heating. These areas are shown in the figure below.

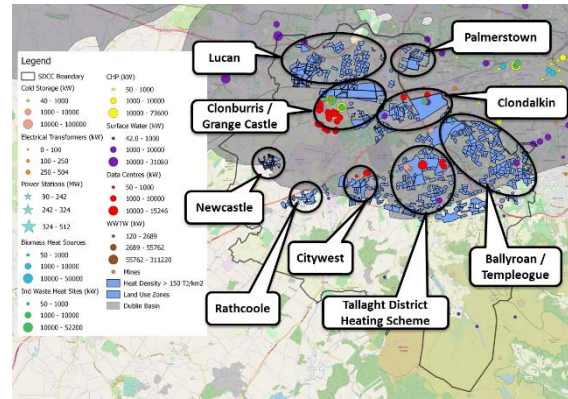

Figure 6: Opportunity Areas Identified

These opportunity areas were then ranked based on heat demand density, proximity to new developments and available heat sources, in order to create a prioritised list of projects to be taken forward to feasibility stage. These rankings can be seen in the table below and are discussed in greater detail in Section 4.4 of this report. Note that the Tallaght District Heating Scheme (TDHS) is not included in this list as it has already successfully gone through feasibility and is currently being procured.

Table 1: Opportunity Area Rankings

Rank	Name
1	Clonburris / Grange Castle
2	Clondalkin
3	Ballymount / Templeogue
4	Palmerstown
5	Lucan
6	Citywest
7	Rathcoole
8	Newcastle

Steps in the Transition

The table of actions shown on the next page was developed and outlines the short, medium, and long term actions designed to catalyse, promote and deliver district heating projects in South Dublin over a seven-year period. A more detailed roadmap that expands slightly on the actions in this table is provided in Appendix A.

Table 2: Transition Roadmap Actions Timeline

	Short Term		Medium Term			Long Term	
	2019	2020	2021	2022	2023	2024	2025
Planning	Develop a heat map	Use and continual improvement of heat maps	Create zoning areas for DH enabled buildings	Further investigation into the geothermal potential			
	High-level ranking of opportunity areas	Feasibility study for high ranking opportunity area	Funding & procurement for feasible project	Development of new DH network	Re-evaluate opportunity area rankings	Funding & procurement for feasible project	Development of new DH network
	Include identified major growth areas in heat map / transition		Create development plan that looks to co-locate high heat demand with heat sources				
		Consider supplying new buildings from the return of older buildings	In 4DHC zones secure provision of thermal storage				
	Locate new development sites close to heat source	Identify areas suitable for locating energy centres and thermal storage	Create low-temperature 4DHC zoning areas				Investigate opportunities to link existing networks
			Consider opportunities for renewable heat sources				
Pilot - Proof of Concept		Develop TDHS as proof of concept		Extend initial TDHS			
Stakeholder Engagement	Continually engage developers / stakeholders		Highlight the whole energy system benefits				
Legal	Develop suite of legal documents		Update legal documents				
Policy	Continually work with national authorities for the inclusion of DH in applicable building regulations	Encourage high density developments with futureproofed centralised systems					
	Planning policy support for generation and distribution of low-carbon heat						
Technical Guidance		Develop secondary system design guidance to improve connectivity					
Capacity Development	Create SDDH Co. - SPV	Develop capacity within SDCC/SDDH Co. to manage the operation of TDHS				Develop capacity within SDCC/SDDH Co. to operate the DH system	

Next Steps

This section discusses the more immediate actions that must be taken to progress the development of DH in South Dublin. These actions are as follows:

- Choose high-ranking opportunity area(s) and develop a feasibility study to determine its suitability for DH
- Continual improvement of the heat map, particularly finding information on industrial waste heat sources that are not part of the EU Emissions Trading System (ETS)
- Set up SDDH Co. special purpose vehicle
- Develop TDHS network – Appoint contractor, construct network and energy centre, develop and sign heat supply agreements, etc. Note that the contracts developed can be used as template contracts for future DH projects
- Look at opportunities to further develop planning policy around DH in SDCC, e.g. encourage higher density new developments in identified opportunity areas that include future-proofed, centralised heating systems – see Section

- 3.2 for policy options used in other regions to promote DH
- Development of secondary system design guides / specs in conjunction with ESCo for TDHS
 - Develop capacity within SDCC/SDDH Co. to manage the operation of the TDHS – hire or assign person within SDCC to work in conjunction with the appointed ESCo to manage TDHS operation (e.g. billing, recording KPIs etc).

1. Introduction

1.1 What is District Heating

A district heating scheme consists of an insulated pipe network, which allows heat generated from a centralised source (energy centre) to be delivered to multiple buildings to provide space heating and hot water.

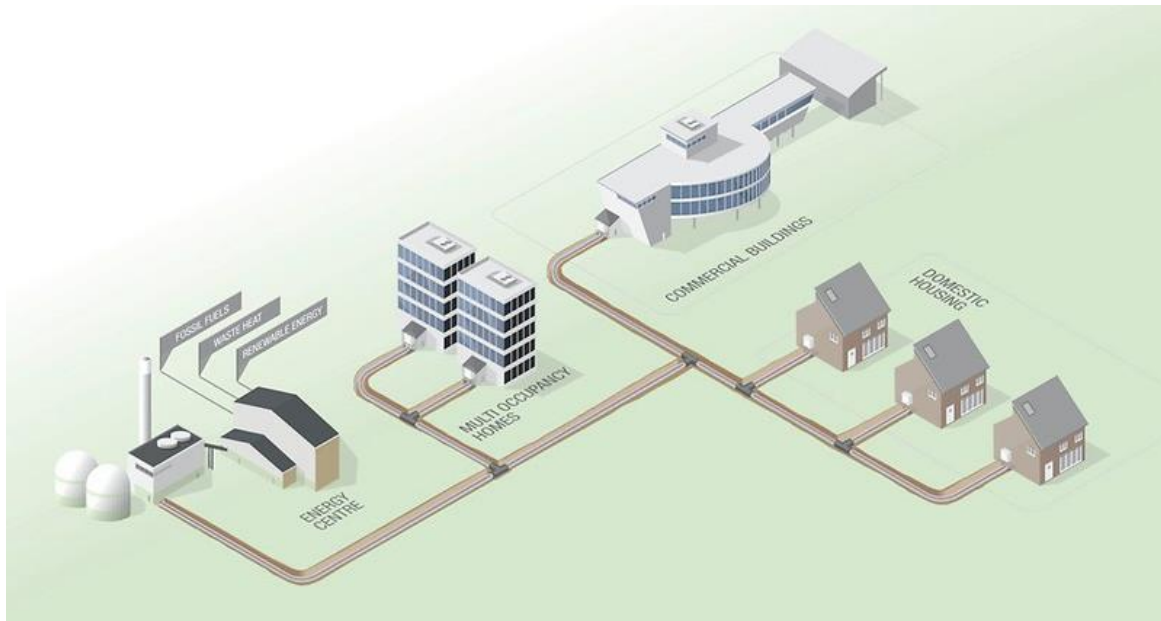

Figure 7: Indicative Diagram of a District Heating System (Source: REHAU)

DH networks benefit from economies of scale, the reduced coincidence of heat demand between different customers leading to lower capacity requirements (when compared with multiple building level units), increased efficiency of larger heat generation units and the reduction in maintenance costs of having a centralised plant. These benefits **allow heat to be generated more efficiently and at a lower cost**. Having fewer, larger heat generation units when compared with having an individual, building-level heating plant also allows for **easier decarbonisation of heat** in the long term, as it requires less individual heating units to be replaced when adopting newer technologies.

District heating is technology agnostic and has the inherent flexibility to **utilise multiple diverse, locally available, renewable and low-carbon heat sources**. This means customers are not dependent upon a single source of supply. This can help guarantee reliability, continuity of service and can introduce an element of competition into the supply chain, where desired. District heating can also allow waste heat (e.g. from electricity generation, industrial processes, etc.) which is often lost, to be captured and used to supply heat to homes and businesses, reducing the need to consume further fuel and significantly reducing carbon emissions and the cost of heat. In a 4th Generation District Heating scheme (4DHC) the temperature of the hot water delivered is reduced; the advantages of this are threefold: the heat lost through the pipes is reduced, the efficiency of the heat generation is often increased and the range of heat sources that can be used is increased as lower temperature heat sources can be used.

Greater utilisation of green electricity can also be achieved through the development of DH networks. For example, heat pumps allow electricity to be converted into heat, which can be stored as thermal energy in the district heating network's pipes and thermal storage vessel, effectively acting as a **large thermal battery**. **This is**

done at a fraction of the cost of other electrical storage methods and allows the electrical grid to be balanced during periods of low electrical demand (e.g. night time). This off-peak demand allows intermittent, renewable generation technologies such as wind turbines to run during these periods, where previously they could not, and thereby increases the green contribution to the local energy system. It is for these reasons that many of the most sustainable countries in the world have a large proportion of heat supplied by district heating systems. For example, DH plays a key role in the sustainability of cities like Copenhagen and Stockholm where more than 98% and 80% of buildings are supplied by a DH network, respectively.

District heating is a low-carbon, low-cost method of supplying heat to a community, district or region and aligns with the energy and climate change ambitions and goals of South Dublin County Council (SDCC) and other local authorities to decarbonise heat in their area. DH has not been widely implemented in Ireland but **there is now an increased focus on methods of decarbonising heat supply as Ireland will not meet EU 2020 renewable energy targets in this area**, and going forward, Ireland's 2030 targets will focus more on CO₂ emissions from the heat and transport energy sectors.

City-wide DH schemes are typically started and developed by establishing a number of smaller, stand-alone networks (or nodes), which are subsequently connected together into a larger scheme. This is particularly typical in publicly-led DH schemes in the UK where the large capital expenditure required to implement a full city-wide scheme may not be easily accessed. Growing a large-scale DH system in this way allows the most financially attractive schemes to be established first, which then support the connection into adjoining areas that may be less financially attractive and ensures successful growth of the network.

1.2 Interreg NWE HeatNet Project Background

HeatNet NWE is a €11.5m Interreg North-West Europe project promoting the roll-out of the most advanced form of district heating, known as 4th Generation District Heating and Cooling, across North-West Europe.

4th Generation District Heating and Cooling integrates heat, electricity and energy storage to achieve an overall smart energy system, combining high energy efficiency, high shares of renewable energy and waste heat resources.

HeatNet NWE will address the challenge of reducing CO₂ emissions in North-West Europe by creating an integrated, transnational approach to the supply of renewable and low-carbon heat (including waste heat) to residential and commercial buildings, developed and tested in local district heating (DH) networks in Ireland, the UK, Belgium, France, and the Netherlands.

In North, East and Central Europe, DH supplies up to 50% of heat demand compared to just 2-7% in North-West Europe and less than 1% in Ireland. DH facilitates energy efficiency, lower CO₂ emissions and a greener economy. The overall objective is to introduce and demonstrate 4th Generation DH (4DHC) in NWE. This is a low-temperature distribution system to minimise heat loss, integrated energy storage and supply to multiple low energy buildings.

The project consists of 13 partners across 5 countries and will result in a saving of 15,000 tonnes of CO₂ each year by the end of the project.

1.3 The Purpose of this Document

Codema developed this report on behalf of South Dublin County Council as part of the Interreg North-West Europe HeatNet project. The objective of the Transition Roadmap is to promote the adoption of DH in South Dublin by highlighting and supporting actions for SDCC that tackle the main challenges in the deployment of DH networks in the region. District heating networks are a key piece of infrastructure that will enable greater cost-effective decarbonisation of heat within the County and help SDCC achieve its CO₂ and energy efficiency targets, as shown below:

- A 33% improvement in the Council's energy efficiency by 2020
- A 40% reduction in the Councils' greenhouse gas emissions by 2030

This report has estimated **the decarbonisation potential of 4DHC in South Dublin to be approximately 250,000 tCO₂ per annum²**. Therefore, the adoption of DH in South Dublin represents a massive opportunity to meet SDCC's carbon reduction target of 40% by 2030, as well as contributing to national energy targets. District heating also has the potential to deliver further benefits for SDCC, as set out in the figure below.



Figure 8: Potential Benefits of District Heating for SDCC (Source: *Developing District Heating in North-West Europe: A Guide for Public Sector Organisations*, Codema (2019))

² Assuming DH in all CSO "small areas", with demand density above 150TJ/km² and a heat supply mix based on the breakdown of sources (by capacity) found in the heat source map

This document draws upon the experience gained by South Dublin County Council and Codema in bringing the Tallaght District Heating Scheme (TDHS) project from an initial concept through pre-planning, feasibility, business case development, stakeholder engagement, funding, planning, procurement and contract development. In progressing the TDHS project, certain barriers and gaps in knowledge (specific to what is a new district heating market in Dublin) were identified. This document addresses many of these barriers to help enable replication throughout South Dublin.

The roadmap suggests actions to be taken in the short, medium and long term to catalyse and promote the development of DH networks in the County; these are discussed in Section 11.1 of this report. Some of these actions have already been taken as part of this report, these are set out below:

- Development of a heat source map
- Combining heat source map with heat demand (SEDA maps + new development zones) and physical constraint maps to act as an evidence base for identify opportunity areas suitable for DH
- Identify opportunity areas with South Dublin
- Create prioritised list of opportunity areas to create pipeline of possible projects to undergo more in-depth feasibility analysis

This report also provides high-level guidance in the following areas:

- How to effectively engage with stakeholders
- Information that can be provided to developers regarding DH
- Policy options that could be considered to support the roll-out of DH networks
- Business model options
- Procurement
- The importance of good quality techno-economic analysis

1.4 How to Use this Document

The diagram below outlines the main areas of the Transition Roadmap and what sections relate to public or private sector readers. It also provides links to other relevant guidance documents developed as part of the HeatNet NWE project.

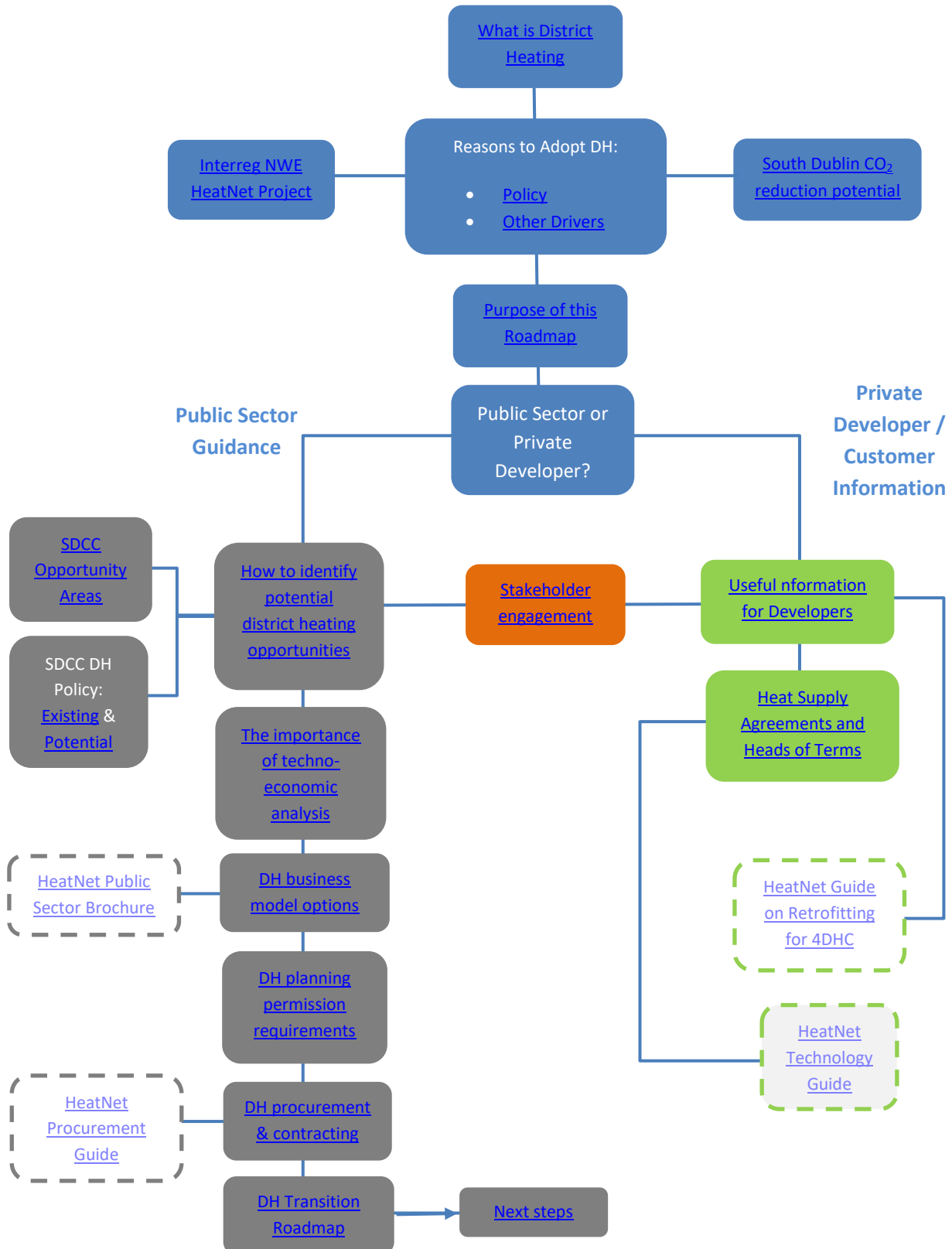

1.5 The South Dublin District Heating Pilot Project – Tallaght District Heating Scheme

The South Dublin County Council Tallaght District Heating Scheme (TDHS) will establish a sustainable district heating solution in the Tallaght area to provide low-carbon heat to public sector, residential and commercial customers. The objective of this project is to decrease the GHG emissions associated with the use of fossil fuels for heating in Tallaght, in order to contribute to national level renewable energy, energy efficiency and CO₂ targets and establish Tallaght as a leader in innovation in the area of climate change. The scheme forms part of the Council’s ambition for the Tallaght Town Centre Local Area Plan.

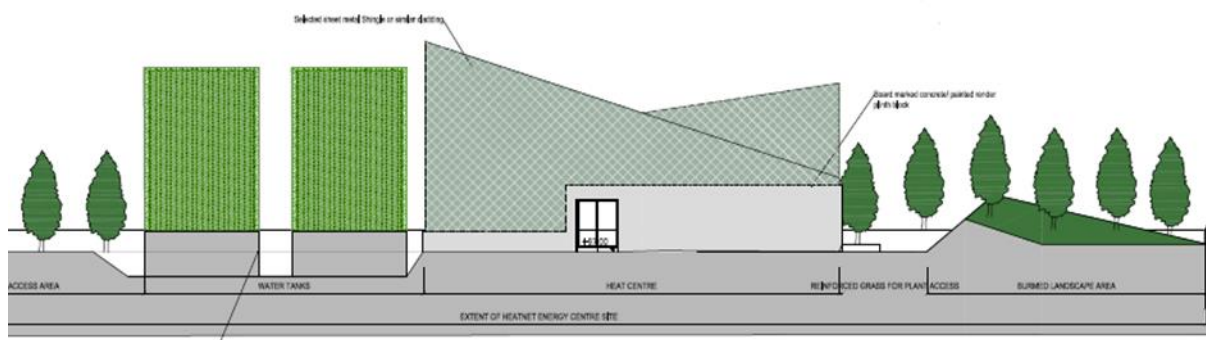

Figure 9: Proposed TDHS Energy Centre Elevation Drawing

This project delivers a high level of innovation in the heating sector, with the first Irish data centre to be used to supply waste heat to heat nearby buildings and will be the only such system in Ireland and the UK. This project will allow transfer of knowledge and replication of solutions for other heat networks based around the growing number of data centres in Ireland. This ability to utilise indigenous heat sources helps to reduce Ireland’s dependence on imported fossil fuels and ensure security of supply for customers into the future. This system also has the potential to catalyse a new low-carbon heating sector in Ireland, generating long-term employment in the operation and maintenance of the scheme over its lifetime, expected to be in excess of 50 years, as well as significant specialised employment during the networks construction.

The first phase of this project will connect existing local authority buildings, new local authority buildings (innovation centre and housing), a new private sector high-density residential/commercial development and the Institute of Technology Tallaght (pending final agreement) to a local heat network. The existing South Dublin County Council buildings connecting to the DH scheme are the County Hall offices and library, the Civic Theatre and the Rua Red building, totalling 27,000m² heated floor area. The new SDCC buildings include a 4,000m² innovation centre with flexible office space and demonstration kitchen area, and a new affordable housing development of 200 1 and 2 bed units, due to for completion by Q3 2021. Connection of the public buildings outlined to the Tallaght District Heating Scheme will have a significant effect on public sector energy efficiency and CO₂ targets, as well as decreasing public spending on energy and fossil fuels.

The new private residential development at Belgard Gardens will comprise of 1,423 apartment units, 339 student units, and 12,250m² of commercial space. This forms a significant part of the plans for a new

redeveloped Tallaght town centre and will be home to more than 3,000 people. All of these dwellings will be supplied by the TDHS, providing those citizens with low-cost, low-carbon, safe, secure, hassle-free heat supply.

The heat network will be supplied by a local, low-grade waste heat source from a data centre, utilised through a centralised, large-scale heat pump, housed in an on-site pump house. The pump house will include thermal storage facilities to take advantage of off-peak electricity and possibly demand response services, while also providing a source of back-up. The energy centre will include back-up to ensure heat supply can be met at all times in the event of any possible primary heat supply failures.

There are many more high-density heat demands in this area, such as high-rise apartments built circa 2006, which are currently heated by old, inefficient electric storage heaters. Retrofitting and connecting these blocks would greatly lower costs for consumers, decrease carbon emissions and help to alleviate fuel poverty in the area.

The DH infrastructure outlined in this project will allow the project to be scaled up and have a direct impact far beyond the current scope outlined in the initial phases. The plan for the TDHS is to connect as many heat demands as possible, switching customers from current fossil fuel heat supply to low-carbon, sustainably-sourced heat supply.

1.6 Support from Senior Council Members

The transition towards 4DHC is supported at the highest level within SDCC with buy-in from the Council’s CEO. In order to facilitate this transition, a number of supporting roles are performed by a team of people within SDCC and Codema; these are set out in the support structure figure below.

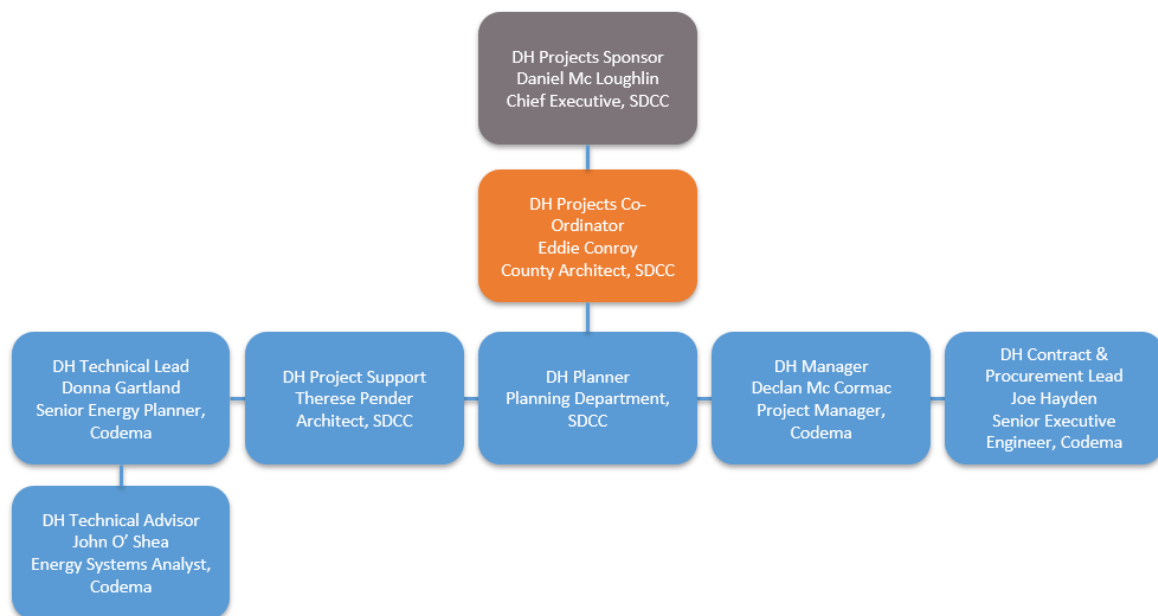

Figure 10: 4DHC Transition Support Structure

2. Supporting Legislation & Policy Context

2.1 EU Level Policy Context

District heating is supported at an EU level and is recognised as a key technology to create low-carbon energy systems, as stated in Article 14 of the Energy Efficiency Directive. This requires Member States to identify the potential for high-efficiency cogeneration and efficient district heating and cooling and to analyse the costs and benefits of the opportunities that may exist. Article 14(4) then requires Member States to take adequate measures to ensure these are developed if there is cost-effective potential.

2.2 National Level Policy Context

The strategic drivers for this investment and associated strategies, programmes and plans are to support and directly impact at a national level:

- The National Mitigation Plan
- Project Ireland 2040 Plan
- Ireland's Transition to a Low Carbon Energy Future 2015-2030
- National Energy Efficiency Action Plan
- National Renewable Energy Action Plan

Ireland has obligations and binding targets in terms of greenhouse gas (GHG) emissions and renewable energy as part of the EU's energy and climate package to 2020 and 2030. Ireland is currently not on a trajectory path to meet 2020 targets for both emissions³ and renewable energy⁴, and is one of only three European countries predicted not to meet these targets.

Looking forward to 2030, member state binding targets are focussed on non-Emission Trading System (ETS) GHG emissions⁵, and these emissions come from agriculture, transport and buildings, rather than the electricity sector, which is covered under the ETS. Therefore, for urban areas like most of South Dublin, decarbonising transport and buildings will be the focus going forward. Emission projections show Ireland will struggle to meet 2030 GHG emission targets. Ireland will face purchasing carbon and renewable compliancy credits from other EU countries, which is estimated, based on the expected target shortfall, to cost up to €490m to achieve 2020 targets alone⁶.

Heating Sector

For buildings, the vast majority of energy consumption and associated emissions comes from the provision of space heating and hot water. A recent report from the Sustainable Energy Authority of Ireland (SEAI)⁷ has shown that Irish homes emit almost 60% more CO₂ than the average EU home, which is the highest emissions per household in Europe. National level policies introduced to date have been partly successful, with 6.8% of

³ EPA GHG Emission Projections to 2020

http://www.epa.ie/pubs/reports/air/airemissions/2020_GHG_Projections_2016_Bulletin.pdf

⁴ SEAI Ireland's Energy Targets report 2016 https://www.seai.ie/resources/publications/Ireland_s-Energy-Targets-Progress-Ambition-and-Impacts.pdf

⁵ https://ec.europa.eu/clima/policies/effort/proposal_en

⁶ IIEA <https://www.iiea.com/climate-and-sustainability/how-much-of-irelands-fiscal-space-will-climate-inaction-consume/>

⁷ SEAI Energy in the Residential Sector 2018 Report <https://www.seai.ie/resources/publications/Energy-in-the-Residential-Sector-2018-Final.pdf>

Ireland’s heating demands now coming from renewable sources, but more than 93% still comes from fossil fuel sources, the majority of which are imported from oil and gas producing regions.

In comparison to Ireland, Sweden provides the majority of its heat demand through either district heating in urban areas, covering around 35% of all residential and service sector heat demand, or through individual heat pumps in more rural areas⁸. The Swedish district heating sector has 93% of its heat provided by renewable sources (see Figure 11 below), and over 50% of electricity in Sweden comes from renewable sources, making heat pumps a very low-carbon solution.

In comparison, Figure 12 on the next page shows a breakdown of Ireland’s energy sources. Of the total energy used in Ireland, 32.5% is used for heat, and only 2% of this comes from renewable energy sources, the vast majority coming from oil and gas.

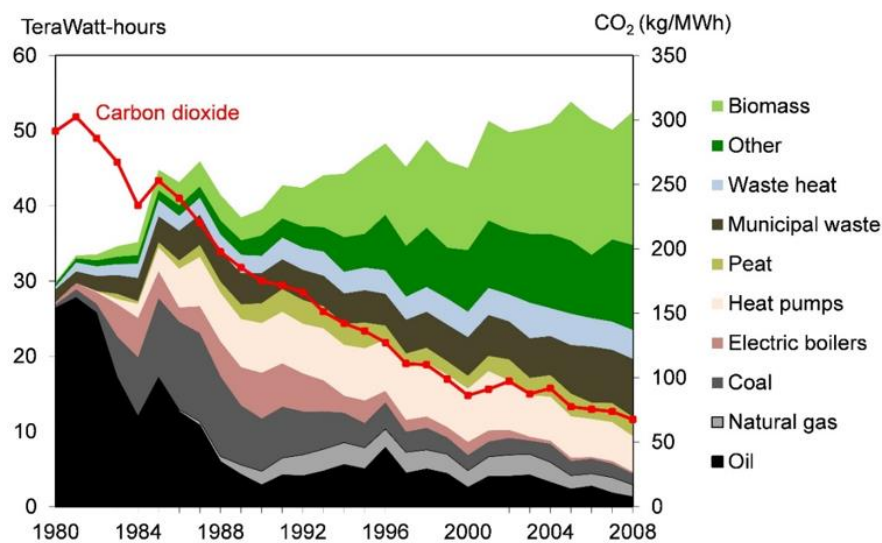

Figure 11: Fuel Sources and Emissions in Swedish District Heating Systems (Source: Nordic Heating & Cooling 2017)

⁸ Nordic Heating & Cooling 2017, <http://norden.diva-portal.org/smash/get/diva2:1098961/FULLTEXT01.pdf>

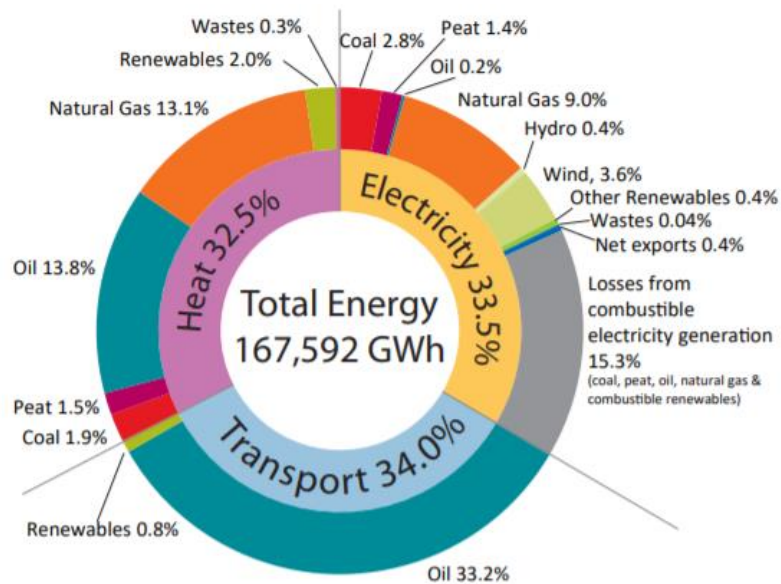

Figure 12: Ireland's Energy Demand and Sources, with Heating Sector highlighted (Source: SEAI)

Under the National Energy Efficiency Action Plan, the public sector must meet 33% energy efficiency targets by 2020. SDCC has undertaken many energy savings measures and has achieved 29.4% of the 33% target so far. Although SDCC is on track to meet the 2020 public sector targets, the remaining energy savings will become increasingly difficult to attain as the 'low-hanging fruit' measures have already been implemented, and further savings will require more radical, innovative and expensive measures.

National Mitigation Plan

Under the Climate Action and Low-Carbon Development Act 2015, the National Mitigation Plan 2017⁹ lays the foundations for transitioning Ireland to a low-carbon, climate resilient and environmentally sustainable economy by 2050. The TDHS project proposed clearly aligns with the objectives of the National Mitigation Plan 2017 in relation to the role of local authorities, as outlined in Chapter 2: *"Local Authorities also have a key role to play in addressing climate change mitigation action and are well placed to assess, exploit and support opportunities within their administrative areas, in cooperation with each other and with national bodies, and through the involvement and support of local communities. The Climate Action and Low-Carbon Development Act, 2015 provides that a Local Authority may adopt mitigation measures in relation to that local authority's administrative area."*

Project Ireland 2040

Under the *Project Ireland 2040: National Development Plan 2018-2027*¹⁰, the National Strategic Outcome (NSO) number eight is the *Transition to a Low-Carbon and Climate-Resilient Society*. This NSO is central to the Ireland 2040 plan, and affects all other areas of the plan. The Strategic Investment Priorities 2018-2027 budget outlined €7.6 billion in Exchequer funding and €14.2 billion in non-Exchequer funding for this NSO. Under this NSO, the plan states the Government will commit funding to *"Support new initiatives in district heating in cities and large towns, with a leading role for state bodies, for example, Gas Networks Ireland and Local Authorities."* Other investment actions outlined which align with the TDHS project are:

- Investment in energy efficiency of existing public building stock with a target BER of 'B'

⁹ National Mitigation Plan <https://www.dccae.gov.ie/en-ie/climate-action/publications/Documents/7/National%20Mitigation%20Plan%202017.pdf>

¹⁰Project Ireland 2040 <http://npi.ie/>

- Climate Action Fund to leverage investment by public and private bodies in climate action measures
- Roll-out of Support Scheme for Renewable Heat

The Sustainable Development Goals National Implementation Plan 2018-2020

Under Ireland’s commitments to the UN Sustainable Development Goals (SDGs), there are 17 agreed SDGs aimed at ending poverty, protecting the environment and strengthening human rights. The TDHS project directly supports the following 5 SDGs:

- 7. Affordable and Clean Energy
- 9. Industry, Innovation and Infrastructure
- 11. Sustainable Cities and Communities
- 12. Responsible Consumption and Production
- 13. Climate Action

2.3 South Dublin Policy Context

South Dublin County Council Development Plan 2016-2022

Addressing climate change mitigation is a central objective of SDCC’s corporate agenda and is a central policy objective of the South Dublin County Council Development Plan 2016-2022. In the Energy chapter of the development plan, SDCC outlines the potential to use the waste heat currently generated by industry in the South Dublin area. *Policy 5: Waste Heat Recovery and Utilisation* objectives 1 to 3 promote the use of waste heat technologies and local energy partnerships with sites that generate heat and sites requiring heat.

Under *Energy Policy 6: Low-Carbon District Heating Networks*, objectives 1 to 4 outline the planning policy developed by SDCC to prioritise the development of DH in low-carbon DH areas of potential, to future-proof the area for DH, and to ensure all new developments carry out energy analyses to explore the potential for DH development.

The project also aligns with SDCC’s objective to increase economic competitiveness and attract and retain investment into the County, including EU and private investment. The TDHS is a key project to enable SDCC to realise its vision for a decarbonised Tallaght town centre.

The South Dublin Spatial Energy Demand Analysis (SEDA)

Codema produced the South Dublin SEDA in 2015, which outlines the heat demand density of the South Dublin area, as shown in Section 4.1. The general area considered for DH development in the Tallaght area is outlined in red. Heat demand density is a key metric for DH viability, as the closer together the heat demands (or heat customers) are, the more customers can be connected over a shorter length of DH pipeline, and therefore the infrastructure capital costs per customer are reduced. A shorter network also means lower operational costs and losses. Reduced investment and operational costs therefore increase the viability of a successful DH system. In Denmark, any areas with a threshold of more than 150 TJ/km² are deemed most viable for DH development. As can be seen, the Tallaght area has the necessary heat demand densities that will support the development of DH, and this is why the area has been identified as the ideal location for the pilot scheme outlined in this report.

Another important factor for successful DH, particularly in the initial phases, is connecting what are termed as ‘anchor loads’ to the network. Anchor loads are heat customers that have one or more of the following attributes: high heat demands, 24-hour heat demand, public sector buildings. The proposed TDHS project in Tallaght has public sector anchor loads in the first phase, and other nearby public sector buildings with high heat demands.

South Dublin Sustainable Energy Action Plan

SDCC is also a signatory to the Covenant of Mayors for Climate and Energy initiative, and as such has committed to implement the EU 40% GHG reduction target by 2030 and the adaptation of a joint approach to tackling mitigation and adaptation to climate change. SDCC has also produced a Climate Change Action Plan 2019-2024, in collaboration with Codema and the other three Dublin Local Authorities, in order to form a regional response to the challenge of climate change. This district heating project will form a key mitigation action for SDCC.

South Dublin Climate Change Action Plan 2019-2024

South Dublin's Climate Change Action Plan 2019-2024¹¹ features a range of actions across five key areas - Energy and Buildings, Transport, Flood Resilience, Nature-Based Solutions and Resource Management - that collectively address the four targets of the plan:

- A 33% improvement in the Council's energy efficiency by 2020
- A 40% reduction in the Councils' greenhouse gas emissions by 2030
- To make Dublin a climate resilient region, by reducing the impacts of future climate change-related events
- To actively engage and inform citizens on climate change

South Dublin County Council is currently on track to achieve its greenhouse gas emissions reduction of 40% by 2030 as shown in the figure below.

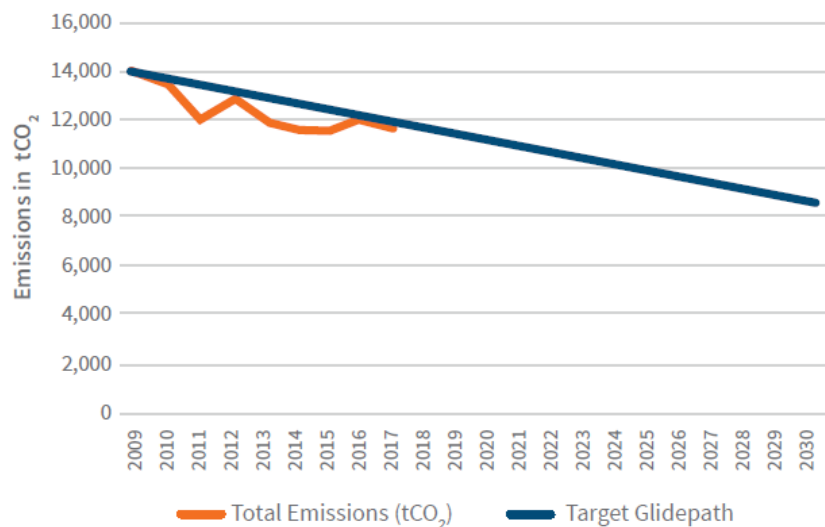

Figure 13: SDCC's Emissions 2009 - 2017, with Projected Glide Path to the 40% Reduction Target by 2030 (Source: South Dublin County Council Draft Climate Change Action Plan, Codema (2019))

The development of the Tallaght District Heating Scheme and Dublin Region Energy Master Plan are listed as some of the main actions for tackling climate change in the area of Energy and Buildings. Buildings and facilities account for 42% of the Councils emissions, as shown in the figure on the next page.

¹¹ South Dublin County Council Draft Climate Change Action Plan 2019 – 2024, Codema (2019) <https://consult.sdublincoco.ie/en/consultation/south-dublin-county-council-draft-climate-change-action-plan-2019-2024-0>

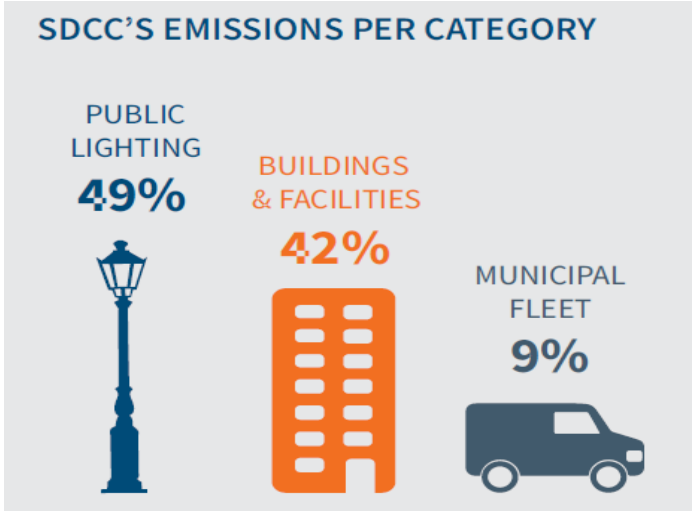

Figure 14: South Dublin County Council Emissions per Category

3. Planning Policy for District Heating

Planners have a key role in driving the development of district heating within a given area. Planners can greatly influence the uptake of district heating in their areas. Some of the mechanisms already adopted by South Dublin County Council are listed below:

- Prioritising low-carbon DH in its planning policy
- Supporting the utilisation of waste heat in its planning policy
- Forward planning of developments that are future-proofed for connection to DH networks

These are discussed in greater detail in the sections below.

There is also a number of innovative planning policy approaches that have been adopted in other countries and regions (e.g. Scotland, Amsterdam, London) in North-West Europe, which may be worth considering to further support the development of 4DHC in South Dublin.

3.1 Current DH Planning Policy Adopted by SDCC

The SDCC Development Plan 2016-2022 sets out a vision and an overall strategy for the proper planning and sustainable development of the County for a six-year period. This document contains an Energy chapter, which promotes the use of waste industrial heat, local energy partnerships and prioritises the development of low-carbon district heating.

The section below shows how the waste heat objective was integrated into the planning process for a new data centre in the form of a forward planning report appraisal and references the local authority's policy (outlined in their Development Plan¹²) regarding the treatment of waste heat.

Waste Heat Utilisation Wording in Forward Planning Report Appraisal

ENERGY (E) Policy 5 Waste Heat Recovery & Utilisation

"It is the policy of the Council to promote the development of waste heat technologies and the utilisation and sharing of waste heat in new or extended industrial and commercial developments, where the processes associated with the primary operation on site generates waste heat.

E5 Objective 1: To promote the development of waste heat technologies and the utilisation and sharing of waste heat, in new or extended industrial and commercial developments, where the processes associated with the primary operation on site generates waste heat.

E5 Objective 2: To promote the development of local energy partnerships among businesses in the County.

E5 Objective 3: To promote increased energy self-sufficiency across business sectors".

¹² https://www.southdublindevplan.ie/sites/default/files/documents/CDP%202016-2022%20%28lower%20res%29_0.pdf

In response to Policy 5 Waste Heat Recovery & Utilisation of the County Development Plan, a Waste Heat Recovery report has been submitted with the application. The report states that given the proximity of the proposed development to Tallaght town centre, ADSIL has actively engaged with SDCC to explore how waste heat from the proposed data storage facility can be integrated into a pilot local district heating network, which is currently being developed by South Dublin County Council in partnership with Codema (Dublin's Energy Agency) and a number of European municipalities, as part of the Interreg North West Europe 'HeatNet' project. The proposed data centre development has been designed to incorporate the provision of Heat Recovery Coils feeding an underground waste heat primary circuit, to be provided by ADSIL, to facilitate this end.

The data centre will utilise Air Handling Units (AHU's) to supply air directly from outside to the data storage rooms for purposes of cooling. The air is warmed as it passes across the IT servers located in the data storage rooms, and subject to external ambient conditions, this air would typically be either recirculated or exhausted directly to the atmosphere. The report submitted states that instead, with the introduction of heat recovery coils within the AHUs, the return air will exchange with ADSIL's waste heat primary water circuit, thereby providing hydraulic heat, to contribute to the proposed SDCC-led pilot local district heating network. The waste heat primary water circuit will deliver waste heat in the temperature range of 15 to 30 degrees Celsius to an energy centre / pump house to be constructed as part of the district heat network on the corner of the ADSIL site, adjacent to the junction of Belgard Road and Airton Road. ADSIL would provide heat meters on the waste heat primary circuit, which would allow for the analysis of available waste heat and its daily and monthly profile. The report also states that construction of the proposed development and the fit out of the first phase will take place over a period of approximately 12 – 18 months from the commencement of construction.

Having regard to the Waste Heat Recovery Report submitted and energy policy objectives of the County Development Plan, it is considered that the waste heat recovery and utilisation proposals are in line with the requirements of the Development Plan in this case and would contribute towards the development of a pilot local district heating network in the Tallaght town centre area. The waste heat measures forming part of the proposed data centre development are innovative and together with the planned pilot district heating project, would represent a significant step forward in South Dublin County's contribution towards addressing climate change mitigation and reducing impacts of greenhouse gas emissions.

Recommendation

It is considered that the proposed development is acceptable subject to the following condition:

Waste Heat Recovery & Utilisation

(a) Proposals for waste-heat recovery and ongoing delivery to a local heat-network shall be provided and implemented on site, in conjunction with the commencement and operation of the proposed development Prior to the commencement of development a timeframe for implementation of waste heat proposals shall be submitted for the written agreement of South Dublin County Council.

(b) Such proposals shall include all necessary infrastructure for waste heat recovery from the proposed development, conversion to hot water and delivery through a primary waste heat water circuit to either, the boundaries of the site or to an Energy centre (when constructed as part of local heat network distribution) for connection to heat network. Such proposals shall be submitted for the written agreement of South Dublin County Council.

(c) Where waste heat recovery and utilisation proposals have been explored and, subject to the written agreement of South Dublin County Council, have been deemed to be technically or otherwise unfeasible, details of future proofing of the building fabric, heat recovery and conversion systems and safeguarding of pipework /

infrastructure routes up to the site boundaries to facilitate future waste heat connection to a local district heating network, shall be submitted for the written agreement of South Dublin County Council.

REASON: To facilitate the development of the use of excess heat in existing and future development, the development of sustainable energy provision, therefore ensuring the proper planning and sustainable development of the area.

District Heating Planning Policy – Policy 6

South Dublin County Council have included the following text regarding the utilisation of district heating in their Development Plan¹³.

Low-Carbon District Heating Networks

(a) It is the policy of the Council to support the development of low-carbon district heating networks across the County based on technologies such as combined heat and power (CHP), large scale heat pumps, and renewable energy opportunities including geothermal energy, energy from waste, biomass and bio-gas.

(b) It is the policy of the Council to support the development of both deep and shallow geothermal energy sources throughout the County. Deep geothermal projects are particularly suited to areas demonstrating high heat densities.

E6 Objective 1: To prioritise the development of low-carbon district heating networks in Low-Carbon District Heating Areas of Potential.

E6 Objective 2: To future proof the built environment in Low-Carbon District Heating Areas of Potential to aid the future realisation of local energy networks and a move towards de-centralised energy systems.

E6 Objective 3: To ensure that all development proposals in Low-Carbon District Heating Areas of Potential carry out an Energy Analysis and explore the potential for the development of low-carbon district heating networks.

E6 Objective 4: To support deep and shallow geothermal projects at appropriate locations across South Dublin County and in accordance with the South Dublin Spatial Energy Demand Analysis (SEDA).

Waste Heat Recovery & Utilisation

Development proposals for new industrial and commercial developments and large extensions to existing premises, where the processes associated with the primary operation of the proposal generates significant waste heat, must:

- Carry out an energy analysis of the proposed development and identify the details of potential waste heat generated and suitability for waste heat recovery and utilisation on site and with adjoining sites, and
- Include heat recovery and re-use technology on site, and

¹³ https://www.southdublindevplan.ie/sites/default/files/documents/CDP%202016-2022%20%28lower%20res%29_0.pdf

- Include heat distribution infrastructure above or below ground (including future-proofing of the building fabric to facilitate future connection, safeguarding any pipe work routes up to the boundary to adjoining sites).

or

- Provide evidence that heat recovery and distribution has been fully explored and is unfeasible.

3.2 Policy Options Adopted in Other Regions

London – The New London Plan

The draft new version of the London Plan¹⁴ states the following.

- A. Boroughs and developers should engage at an early stage with relevant energy companies and bodies to establish the future energy requirements and infrastructure arising from large-scale development proposals such as Opportunity Areas, Town Centres, other growth areas or clusters of significant new development.
- B. Energy masterplans should be developed for large-scale development locations which establish the most effective energy supply options. Energy masterplans should identify:
 1. major heat loads (including anchor heat loads, with particular reference to sites such as universities, hospitals and social housing)
 2. heat loads from existing buildings that can be connected to future phases of a heat network
 3. major heat supply plant
 4. possible opportunities to utilise energy from waste
 5. secondary heat sources
 6. opportunities for low temperature heat networks
 7. possible land for energy centres and/or energy storage
 8. possible heating and cooling network routes
 9. opportunities for futureproofing utility infrastructure networks to minimise the impact from road works
 10. infrastructure and land requirements for electricity and gas supplies
 11. implementation options for delivering feasible projects, considering issues of procurement, funding and risk, and the role of the public sector.
- C. Development Plans should:

¹⁴ Policy SI3 Energy Infrastructure - <https://www.london.gov.uk/what-we-do/planning/london-plan/new-london-plan/draft-new-london-plan/chapter-9-sustainable-infrastructure/policy-si3-energy>

1. identify the need for, and suitable sites for, any necessary energy infrastructure requirements including upgrades to existing infrastructure
 2. identify existing heating and cooling networks and opportunities for expanding existing networks and establishing new networks.
- D. Major development proposals within Heat Network Priority Areas should have a communal heating system
1. the heat source for the communal heating system should be selected in accordance with the following heating hierarchy:
 - a. connect to local existing or planned heat networks
 - b. use available local secondary heat sources (in conjunction with heat pump, if required, and a lower temperature heating system)
 - c. generate clean heat and/or power from zero-emission sources
 - d. use fuel cells (if using natural gas in areas where legal air quality limits are exceeded all development proposals must provide evidence to show that any emissions related to energy generation will be equivalent or lower than those of an ultra-low NOx gas boiler)
 - e. use low emission combined heat and power (CHP) (in areas where legal air quality limits are exceeded all development proposals must provide evidence to show that any emissions related to energy generation will be equivalent or lower than those of an ultra-low NOx gas boiler)
 - f. use ultra-low NOx gas boilers.
 2. CHP and ultra-low NOx gas boiler communal or district heating systems should be designed to ensure that there is no significant impact on local air quality.
 3. Where a heat network is planned but not yet in existence the development should be designed for connection at a later date.

Developments should connect to existing heat networks, wherever feasible. Stimulating the delivery of new district heating infrastructure enables the opportunities that district heating can deliver to be maximised. The Mayor has identified Heat Network Priority Areas, which can be found on the London Heat Map website¹⁵. These identify where in London the heat density is sufficient for heat networks to provide a competitive solution for supplying heat to buildings and consumers. Data relating to new and expanded networks will be regularly captured and made publicly available.

Where developments are proposed within Heat Network Priority Areas but are beyond existing heat networks, the heating system should be designed to facilitate future connection. This may include for example, allocating space in plant rooms for heat exchangers, safeguarding suitable routes for pipework and making provision for connections at the site boundary. The Mayor is taking a more direct role in the delivery of heat networks so that more new and existing communally-heated developments will be able to connect into them, and has developed

¹⁵ <https://www.london.gov.uk/what-we-do/environment/energy/london-heat-map>

a comprehensive decentralised energy support package. Further details are available in the London Environment Strategy.

The current London Plan states¹⁶, that where an opportunity for a district energy network is taken forward, the borough should connect its own buildings to the network wherever possible and identify potential sites for energy centres on either council owned land or in buildings. The Greater London Area (GLA) is developing decentralised energy technical specifications and standards in conjunction with the boroughs and other relevant stakeholders to ensure compatibility between decentralised energy networks as they are developed in London. Boroughs are encouraged to make use of these specifications and standards when developing network opportunities in their borough. They may also wish to explore the use of local development orders (LDOs) for implementation purposes.

Amsterdam

Currently 90% of homes in Amsterdam are heated using natural gas. Amsterdam aims to eliminate gas-fired central heating by 2050 and has already begun to implement this objective with 10,000 new public housing units having their gas supplies removed, with various district heating options taking their place. New neighbourhoods in the city will also not have natural gas as an option. It is estimated that by 2020, 102,000 Amsterdam homes will have switched to district heating.

Scotland

Scottish government has provided guidance which states that policies should¹⁷:

- Support safeguarding of pipe runs within developments for later connection and pipework to the curtilage of development
- Give consideration to the provision of energy centres (a boiler or CHP or a pumping plant with large storage tank) within new developments
- Where a district network exists, or is planned, or in areas identified as appropriate for district heating, policies may include a requirement for new development to include infrastructure for connection, providing the option to use heat from the network
- Secure provision for a heat storage tank from non-renewable sources if there is potential to switch to renewable sources within the lifetime of the development
- Encourage micro-generation and heat recovery technologies associated with individual properties where heat networks are not viable

progRESsHEAT Project Countries (Denmark, Germany, Portugal, Czech Republic, Austria, Romania) Policy Recommendations

The progRESsHEAT Project¹⁸ provides policy recommendations at European, national and local level in the heating and cooling sector, these are summarised in the figure on the next page.

¹⁶ Policy 5.5 Decentralised energy networks

¹⁷ <https://www.gov.scot/binaries/content/documents/govscot/publications/advice-and-guidance/2013/06/heat-demands-planning-advice/documents/817906cc-fcce-4865-946f-6995038020eb/817906cc-fcce-4865-946f-6995038020eb/govscot%3Adocument>

¹⁸ Policy recommendations to decarbonise European heating and cooling systems (progRESsHEAT Report, 2017) http://www.progressheat.eu/IMG/pdf/progressheat_d5.5_inclannex_forupload_2017-12-06.pdf

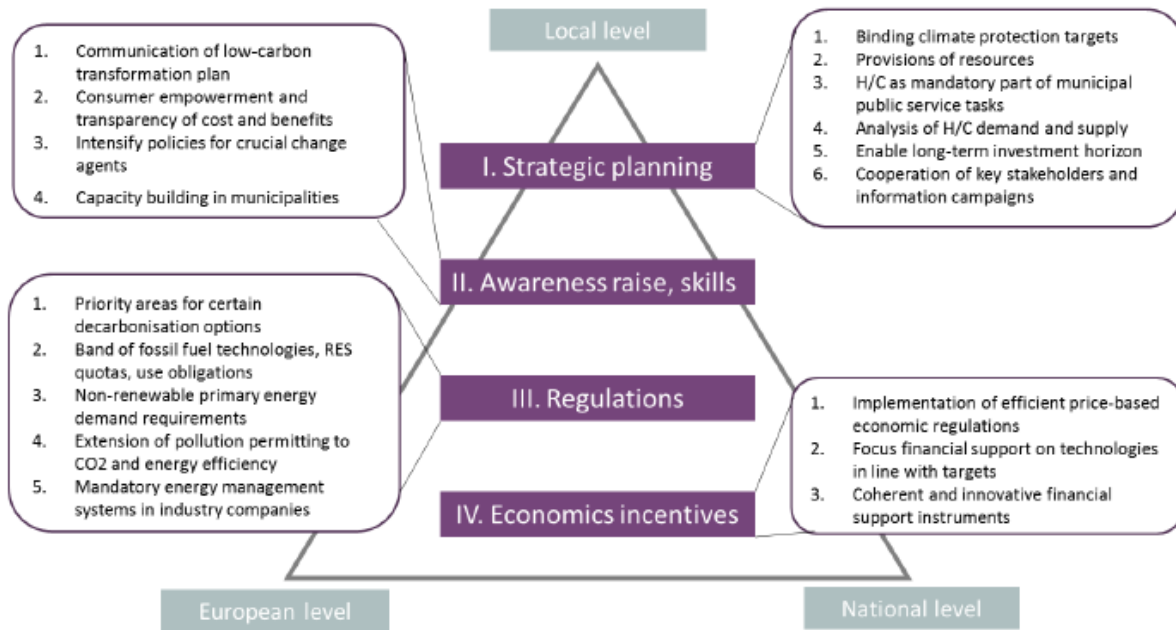

Figure 15: Overview of progRESsHEAT Policy Recommendations¹⁹

3.3 Forward Planning & Future-proofing

Forward planning is also essential to ensure there is sufficient heat demand to connect to any proposed DH network; this will allow the network to operate cost-effectively into the future and realise its full decarbonising potential. In South Dublin County Council, planners were able to provide details of future planned developments (from the South Dublin Local Area Plan) allowing the DH network to be routed so that these future developments could be more easily integrated into the network. SDCC also provides zoning maps, which indicates the preferred development type in a given area; this can be used to identify DH opportunities, e.g. if new, high-density housing is preferred, it may be prudent to include a flange to allow future connection of this zone to the DH scheme.

As mentioned previously, Codema developed a SEDA analysis, which provided information on the current and future energy demand and local energy resources of the South Dublin area, within a spatial context. The Council has since built upon this evidence-based approach to undertake the Clonburris Strategic Development Zone (SDZ) Energy Master Plan and the Grange Castle Business Park Energy Master Plan, both of which were supported by the Sustainable Energy Authority of Ireland (SEAI). The Clonburris Master Plan also identified Clonburris and Kishogue urban centres as potentially viable areas for local heat networks. The Clonburris Energy Master Plan recommends that all major developments within these two urban centres should be designed to be able to connect to a local heat network in the future if or when such a network becomes available in the future.

¹⁹ Policy recommendations to decarbonise European heating and cooling systems (progRESsHEAT Report, 2017) http://www.progressheat.eu/IMG/pdf/progressheat_d5.5_inclannex_forupload_2017-12-06.pdf

4. Energy Master-Planning: Identifying District Heating Opportunity Areas

The development of integrated energy planning and mapping is considered best practice to identify synergies and opportunities for cost-effective district energy systems. In many cases, spatial heat maps have been used to bring together stakeholders for business development and to share opportunities, inform policy and optimise network design.

The purpose of identifying opportunity areas is to highlight areas within the County that warrant greater investigation into the technological feasibility and financial viability of utilising district heating networks through more detailed techno-economic analysis. The best DH opportunity areas are those that have:

- High heat demand density (both existing and planned)
- Proximity to existing heat sources
- Minimal spatial/physical barriers along DH network route (e.g. rivers, existing infrastructure, heritage sites etc.)

These key indicators of the suitability of an area to DH have been represented spatially using GIS software and the resulting opportunity areas can be seen in Section 4.4 of this report.

4.1 Heat Demand

In the case of heat demand, CSO Small Areas have been used as the geographical boundaries to spatially represent South Dublin's heat density across the commercial, residential and municipal sectors. This is shown in the figure overleaf. The objectives and methodology used in calculating these demand densities can be found in the South Dublin Spatial Energy Demand Analysis report²⁰ prepared by Codema in association with South Dublin County Council.

The area outlined in red includes three of the top ten heat demand density areas in the County, which are linked by areas with heat demand density in excess of 150 TJ/km² (the threshold used in Denmark to designate areas as DH viable). It is also worth noting that development plans within this area include over 1,500 residential units, mixed-use developments, an innovation centre and a proposed school. It is in this area that the TDHS pilot project is being developed.

²⁰ http://www.codema.ie/images/uploads/docs/South_Dublin_Spatial_Energy_Demand_Analysis_Final.pdf

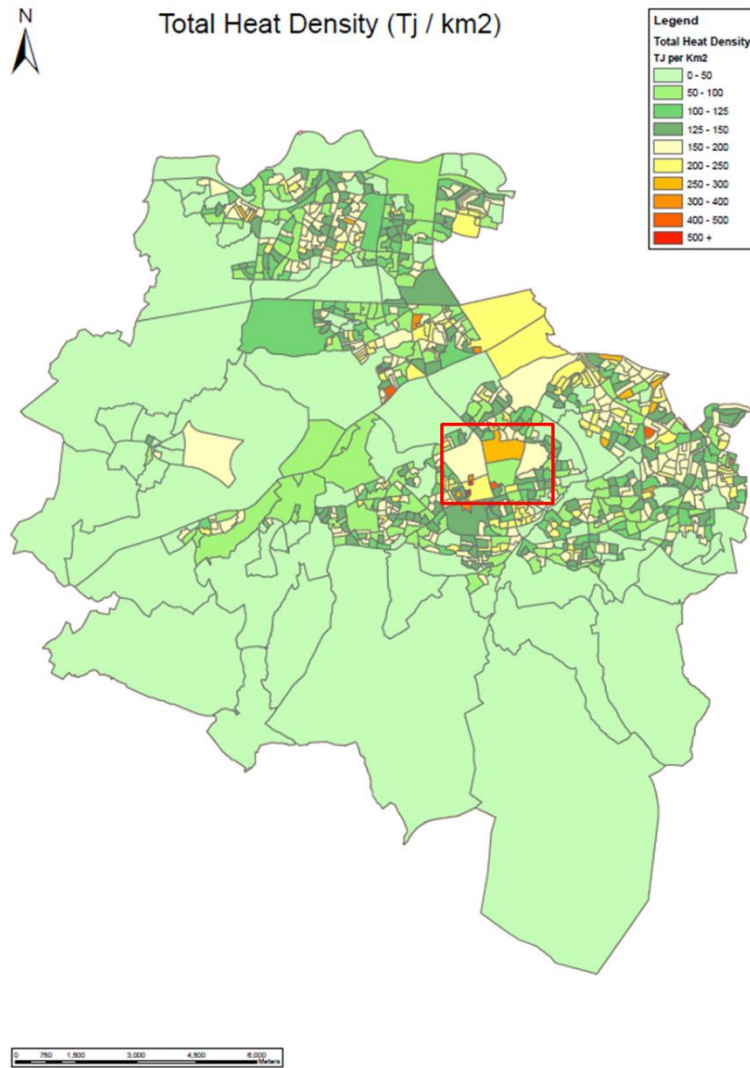

Figure 16: South Dublin Spatial Energy Demand Analysis Map

Codema has also mapped the development zones as a means of identifying possible future heat demand. The zones of particular interest in this regard are the strategic development zones (SDZs), new residential zones (RES-N) and residential-led regeneration zones (REGEN). This includes the Clonburris SDZ, and within this, Clonburris and Kishogue urban centres have been identified through its Energy Master Plan as potentially viable areas for local heat networks. The Clonburris Energy Master Plan also recommends that all major developments within these two urban centres should be designed to be able to connect to a local heat network in the future if or when such a network becomes available.

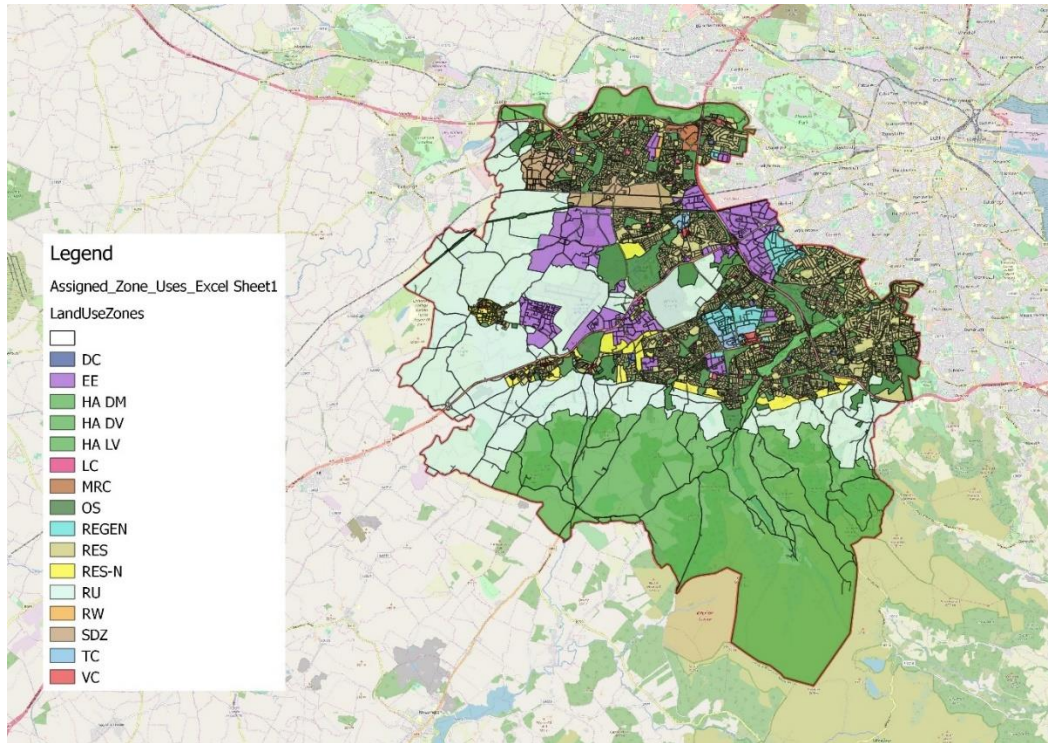

Figure 17: SDCC Land Use Zones

The table below gives a description for the various abbreviations used in the SDCC Land Use Zones map above.

Table 3: Land Use Abbreviation Description

Land Use Reference	Land Use Zone Description
DC	District centres
EE	Enterprise and employment
HA DM	Heritage area Dublin Mountains
HA DV	Heritage area Dodder Valley
HA LV	Heritage area Liffey Valley
LC	Local centre
MRC	Major retail centre
OS	Open space
REGEN	Residential-led regeneration
RES	Residential
RES-N	New residential
RU	Rural
RW	Retail warehousing
SDZ	Strategic development zone
TC	Town centre
VC	Village centre

A map combining both existing high-density demands and future heat demands in the form of the relevant land use zones discussed above (SDZ, RES-N and REGEN) was produced to help indicate the areas where district heating may be most suited.

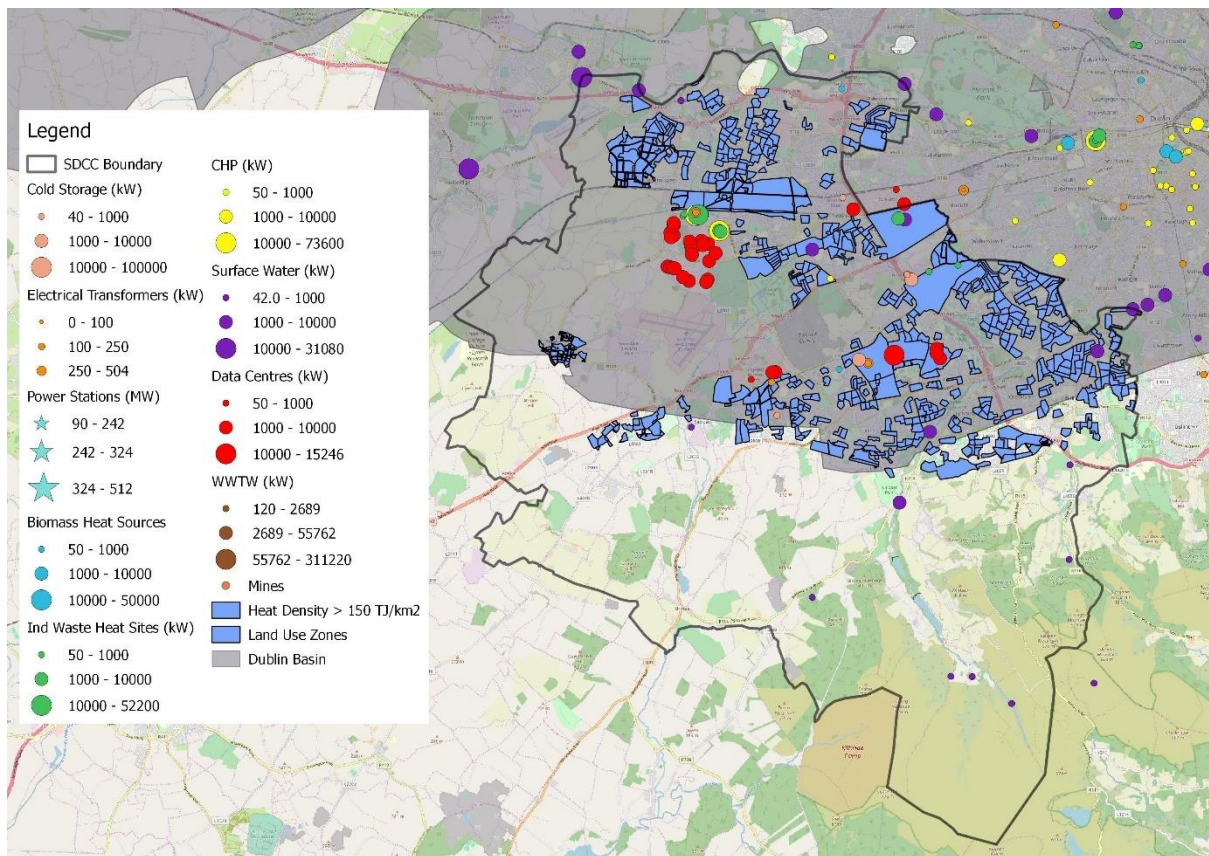

Figure 18: Combined Heat Source, Heat Demand and Relevant Development Zone (RES-N, REGEN & SDZ) Map

4.2 Heat Sources

Heat Sources Summary

The use of existing local heat sources can provide many advantages to a DH network, such as:

- Increased security of supply
- Lower cost or free heat, as it is already being lost to the environment – improving the economic case for the DH system
- Lower or zero carbon emissions, as it is a by-product of a separate primary process – reducing emissions associated with heating
- Where heat pumps are being used, district heating networks can be used to balance the electricity grid and increase the proportion of renewable energy that can be utilised

Heat sources that arise as a by-product of electricity generation, industrial activity, the natural environment or from existing infrastructure are low or zero carbon and often go to waste. It was estimated by Codema that almost 500 MW of heat from these sources (including both low-grade and high-grade heat) is currently being wasted in South Dublin, equating to approximately 4,000 GWh of wasted heat per annum (enough to serve approximately 1.2 million dwellings²¹) which is approximately 1.5 times the total heat demand for all buildings

²¹ Dwelling assumed to be a two-bedroom apartment built in accordance with the most recent building regulations (BER rating A3)

in South Dublin. These sources could reduce the total fossil fuel bill for South Dublin by up to €280 million per year²² and reduce the region's exposure to price fluctuations and security of supply issues in the oil and gas markets. The flexibility offered by DH supply means it is possible to continually connect new, secure, local sources to the network. This also offers increased price stability and security for customers.

The heat source map created by Codema assesses 18 different heat source types in the county and utilises data from approximately 70 different sources. This map can be seen in Figure 19 on the next page. The heat sources that were assessed are listed below, with more details on what they are and how they were quantified given in the Heat Source Descriptions and Assessment Methodology sections, section 4.2 and Appendix C respectively.

Commercial Sources:

- Flue gas heat recovery
- Industrial process heat recovery
- Commercial CHP excess heat
- Excess heat from existing biomass installations
- Commercial building cooling system waste heat (e.g. data centres, cold storage facilities)

Infrastructural Sources:

- Power plant waste heat (Energy from Waste (EfW) and conventional power stations)
- Electrical transformer waste heat
- Landfill waste heat
- Landfill biogas
- Waste water treatment works (WWTW) waste heat
- WWTW biogas/sludge incineration
- Sewage pipe waste heat

Environmental Sources:

- Air-source heat pumps
- Surface water (rivers, lakes, canals)
- Seawater
- Ground source heat pumps (shallow)
- Deep geothermal
- Mine water

²² Assuming 0.07 €/kWh for the cost of heat and that all the heat sources identified could be fully utilised

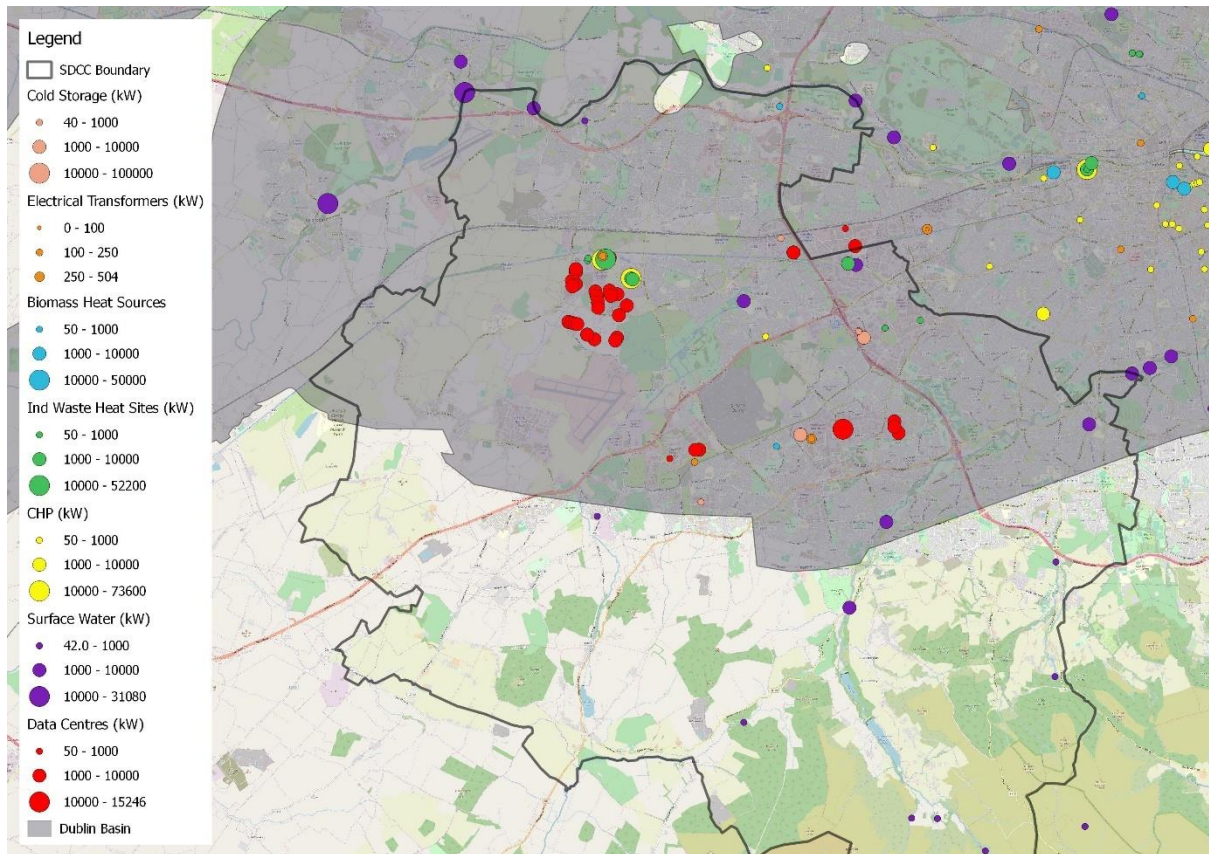

Figure 19: South Dublin Heat Source Map

Heat Source Breakdown

This section of the roadmap summarises the total capacity and quantity of heat sources identified with the South Dublin region.

The heat source which has the greatest heat capacity in Figure 20 is data centre waste heat. At 206 MW, this is enough heat to supply the peak heat demand of 70,000 dwellings.

It should be noted that the capacity figure for the surface water heat loads (marked with an Asterisk) shown in Figure 20 on the next page is conservative as it is based on the Q95 flow. This flow rate was chosen based on the assumption that the source are fisheries and as such, have limits on the degree to which their original temperature can be altered without adverse impacts on the fishery. This also assumes a constant heat extraction rate. It may be possible to have variable extraction controlled by the source temperature to prevent excessive cooling of the source. Under these conditions the mean flow could be used, this would increase the potential heat capacity from surface water by a factor of seven. If it was assumed that there is no impact on fisheries and therefore that the reduction in river temperature is only limited by technical constraints, then this capacity could increase by a factor of 12 compared to what is shown in the graph to approximately 510 MW.

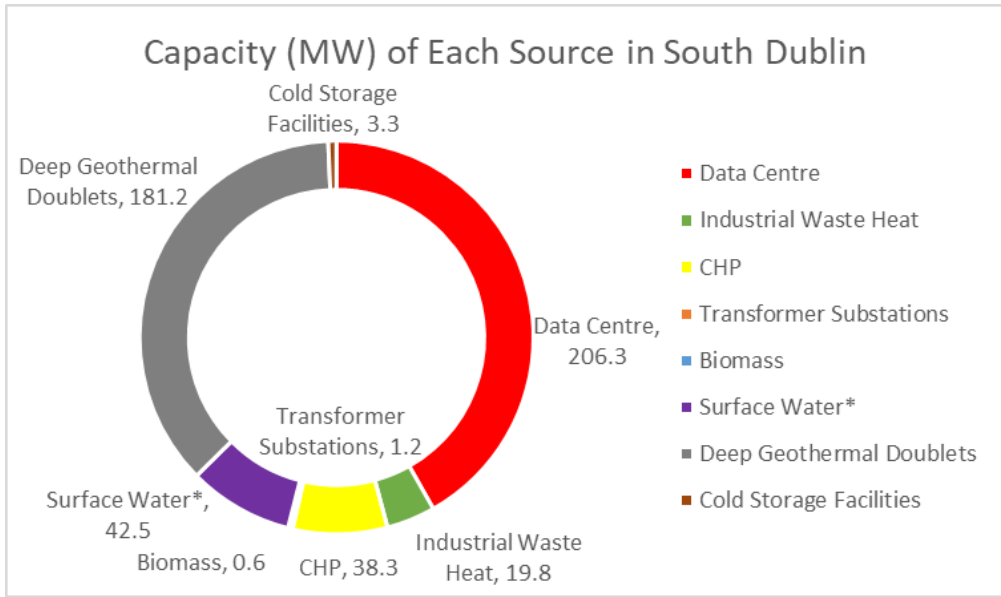

Figure 20: Heat Sources Identified by Capacity (MW)

The number of heat sources grouped by type are shown in the figure below. This helps to give an indication of the replicability of adopting certain heat sources. It should be noted that this is not a fully exhaustive list of the potential heat sources in South Dublin and only shows sources for which details could be found.

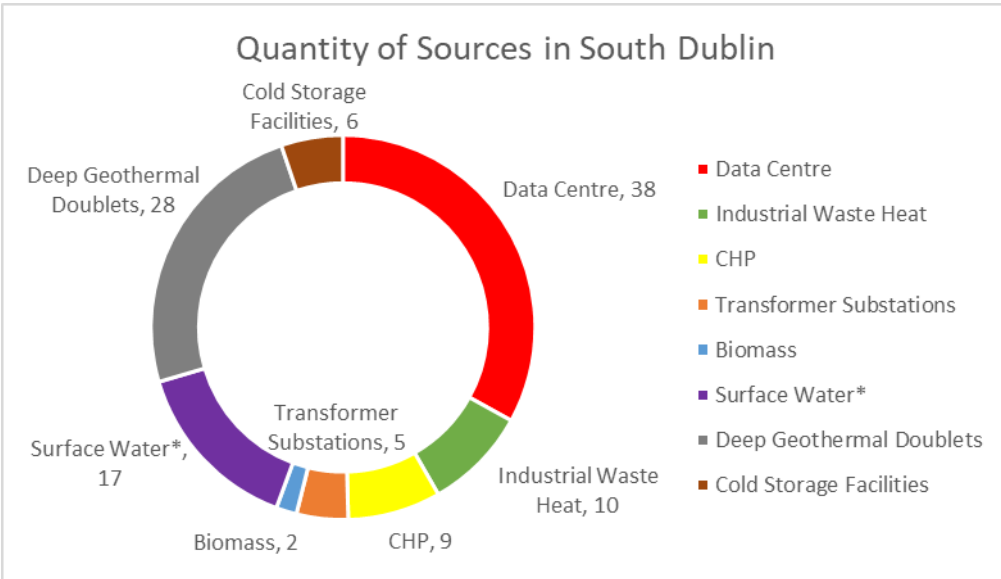

Figure 21: Number of Heat Sources Sites Identified - Grouped by Type

Heat Source Descriptions

This section of the report provides a general description of each of the heat sources investigated in creating the South Dublin heat source map.

Table 4: Description of Heat Sources Investigated

Category	Source	Description
Commercial	Flue gas heat recovery	Hot flue gases are produced when fuel or waste gases are combusted in boilers, combined heat and power units, and thermal oxidisers. The heat from these gases can be captured and used to heat water for the DH system. The quantity of heat available depends on the flue gas temperature and flow rate which varies based on the number, size and type of heating unit being used and the heat or waste gas combustion load it needs to serve.
	Industrial process heat recovery	Many industrial processes result in the production of waste heat, which do not take the form of exhaust gases from combustion. In this study, these include industrial sites, breweries, pharmaceutical plants and metal processing plants. Details of individual process heat producers were not available for these sites and so the waste heat was taken as being the heat rejected to sewer for each site.
	Commercial / industrial sites with CHP	Some commercial and industrial sites will have on-site cogeneration / combined heat and power (CHP) units to provide both heat and electricity to the site. Connecting existing CHP plants to a DH network could result in mutual benefits for both the CHP operator and the DH network. By increasing the potential heat demand for the CHP, its run hours and electricity generation can be increased, the heat rejection and associated costs are reduced, and the CO ₂ emissions are reduced due to greater electrical generation and use of the heat that would previously have been rejected.
	Commercial / Industrial cooling (e.g. data centres, cold storage facilities, hotels, offices)	Certain commercial and industrial buildings require a significant amount of cooling, which results in significant heat rejection. This heat can be converted to a usable temperature for a district heating system via a heat pump. The types of buildings in this study use this cooling for comfort cooling, IT equipment cooling, food storage and refrigeration, etc. The main building types assessed were data centres, cold storage facilities and industrial sites. The quantity of heat available will vary depending on the cooling system used and the operational cooling requirement.
Infrastructural	Power plant (EfW or other)	Power plants burn fuel to generate electricity. Their electrical generation efficiency is typically between 30% and 50% depending on the technology and fuel being used. This process also generates high-grade waste heat. There are two main types of conventional power plant: Open Cycle Gas Turbines (OCGT) and Combined Cycle Gas Turbines (CCGT). In the case of OCGT, the hot exhaust gas is rejected to atmosphere through a flue system. In the CCGT, some heat is rejected to the atmosphere via a flue system and some is rejected to the steam condenser. There are also less conventional power plants called Energy from Waste (EfW) facilities, a.k.a. Waste to Energy (WtE), which combust waste to produce steam for the turbines to generate electricity (Steam Cycle). The waste heat in an EfW facility can be captured from the flue system and the steam condenser.
	Electrical transformers	Electrical transformer sub-stations convert electrical power from one voltage to another. During this process a certain amount of electrical power is lost and converted into heat. These transformers are kept cool and insulated by being immersed in insulation oil or by fans in air-cooled transformers. The

		heat from these transformers can be extracted for use in a district heating system.
	Landfill (biogas & waste heat)	Landfill gas is formed when biodegradable material in the landfill decomposes. This chemical reaction also gives off heat, which can be captured via a closed loop collector connected to a heat pump. The landfill gas can also be used to fuel a boiler or CHP unit to generate heat and electricity.
	WWTW (waste heat, biogas/sludge incineration)	Waste water contains a certain amount of organic matter. When this material breaks down, it can form biogas which can be used to fuel a boiler or CHP unit to generate heat and electricity. Heat can also be extracted from the waste water itself in the same way that heat is extracted from surface water. This heat extraction usually takes place in the WWTW tertiary tanks via a heat exchanger connected to a heat pump.
	Sewage pipes waste heat	Sewage in underground sewage pipes contains heat which can be extracted through various types of heat exchanger. This can provide heat at a usable temperature for a district heating network by passing it through a heat pump.
Environmental	Air-source heat pump	Air source heat pumps extract heat from the outside air. These heat pumps give lower efficiencies than water source or ground source heat pumps due to the comparatively lower heat source (air) temperature during the main heating season.
	Surface water (rivers, lakes, canals)	Surface water sources such as rivers and canals contain a certain amount of heat, which can be extracted via a heat pump. The quantity of heat that can be extracted is dependent on the river's flow and water temperature and maximum allowable reduction in temperature that can be achieved without any negative impact on the environment.
	Seawater	Seawater source heat pumps utilise the thermal energy stored in the sea. This heat can be extracted via a heat pump. The quantity of heat that can be extracted is dependent on the maximum allowable reduction in temperature that can be achieved without any negative impact on the environment.
	Ground source heat pump	Ground source heat pumps extract heat from the ground. Heat can be extracted from open or closed loop heat pumps, the former using aquifers, the latter boreholes or horizontal collectors. The amount of heat that can be extracted depends on the quantity of suitable land that is available to install collectors or in the case of open loop systems, the maximum ground water extraction rate.
	Deep geothermal	The earth's temperature increases the deeper you drill. Deep geothermal systems extract this heat by pumping water out of deep borehole to the surface where it can be used, once the heat is extracted this water is then pumped back into the earth. Certain areas have a higher heating potential than others based on their geological composition. In areas where source temperatures of greater than 60°C can be achieved, the DH system may not require a heat pump as the water extracted is already at a usable temperature. In other areas, high-efficiency heat pumps can be used to raise

		<p>the temperature to the required level. This study looks at the potential of such systems within South County Dublin.</p> <p>Geothermal energy has proven to be secure, environmentally sustainable and cost effective over long-term periods. The complete security of supply of geothermal energy makes it a particularly attractive energy solution. High-temperature geothermal resources are commonly found in volcanic regions near active tectonic plate boundaries (e.g., Iceland). Despite its position far from any plate boundaries, Ireland has recognised potential for deep geothermal energy in sedimentary basins in the south and east, and Northern Ireland (SLR's Play Fairway Analysis report, 2011; GeoDH report, 2014; outputs of IRETherm project, 2016).</p> <p>In recent decades, improvements in drilling and geothermal technologies, coupled with policy-driven pursuit of secure and low-carbon energy sources, has led to the development of geothermal district heating in several low-temperature geothermal settings in the EU (e.g. France, the UK, Denmark and the Netherlands).</p>
	<p>Mine water</p>	<p>Mines are prone to flooding by ground water. This ground water is warmer than surface water due to the increased ground temperatures at greater depths, this higher temperature results in an increase in the Coefficient of Performance (CoP) when passed through a heat pump to convert the heat to a usable temperature. The quantity of heat that can be extracted depends on the maximum extraction flow rate and the temperature of the groundwater.</p>

4.3 Physical/Spatial Constraints

There are certain physical constraints that need to be considered when assessing the suitability of an area for district heating. These mostly impact the routing of the pipe network and the implications this will have on cost, e.g. for crossing roads, railways, canals, rivers, environmentally sensitive areas, heritage sites, etc. The following constraints layers have been mapped using GIS software (as shown in the figure on the next page) to identify areas where due consideration should be given to these pipe installation constraints.

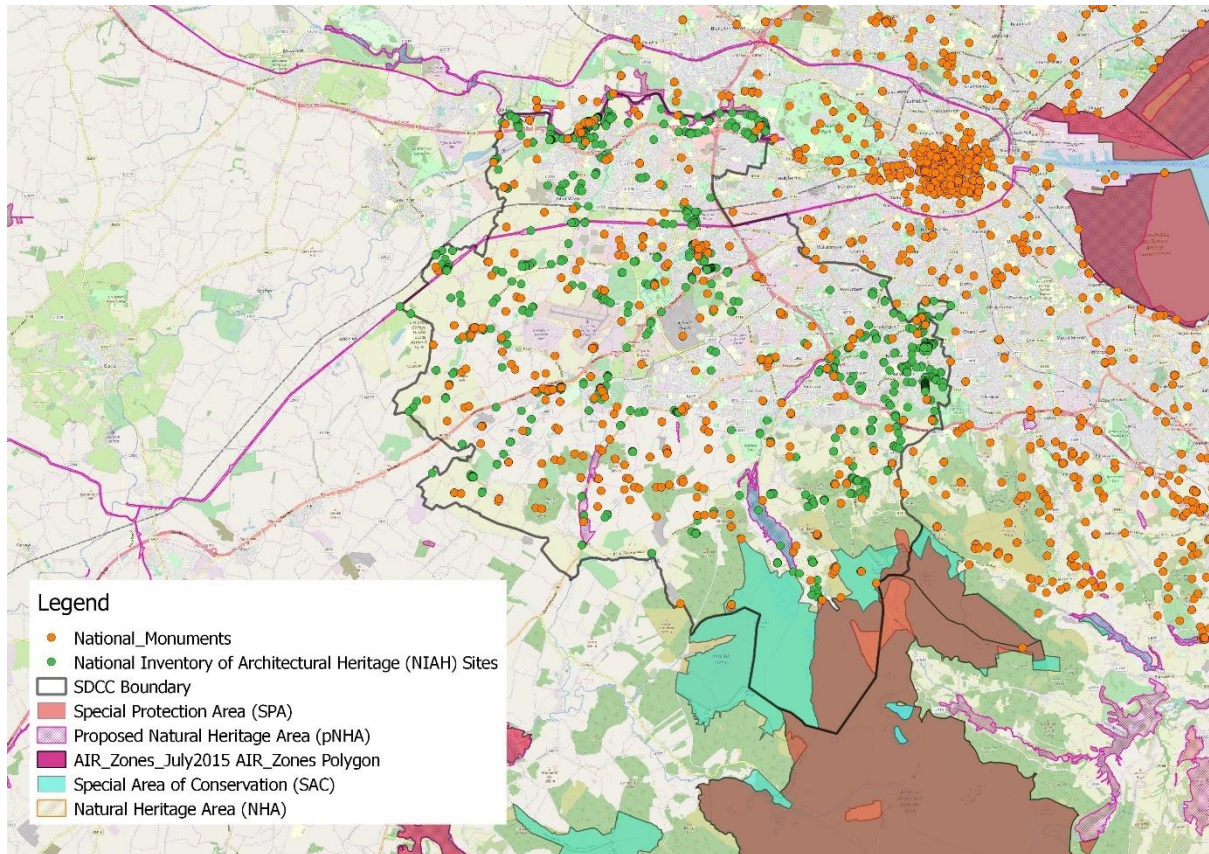

Figure 22: South Dublin Constraints Map

1.4 Opportunity Areas Identified

Identification Methodology

Codema developed a map to be used for the purpose of identifying the best district heating opportunity areas (see next page). This map represents the areas that have a heat demand density that is considered sufficient for connection to a DH system as blue polygons. These blue areas have a heat density in excess of 150TJ/km² or are zoned for relevant future development (e.g. SDZ, REGEN, RES-N). This map was then overlaid with the heat source data points. The resulting map allowed the identification of eight opportunity areas, with the best of these having the blue heat demand areas in close proximity to an existing heat source.

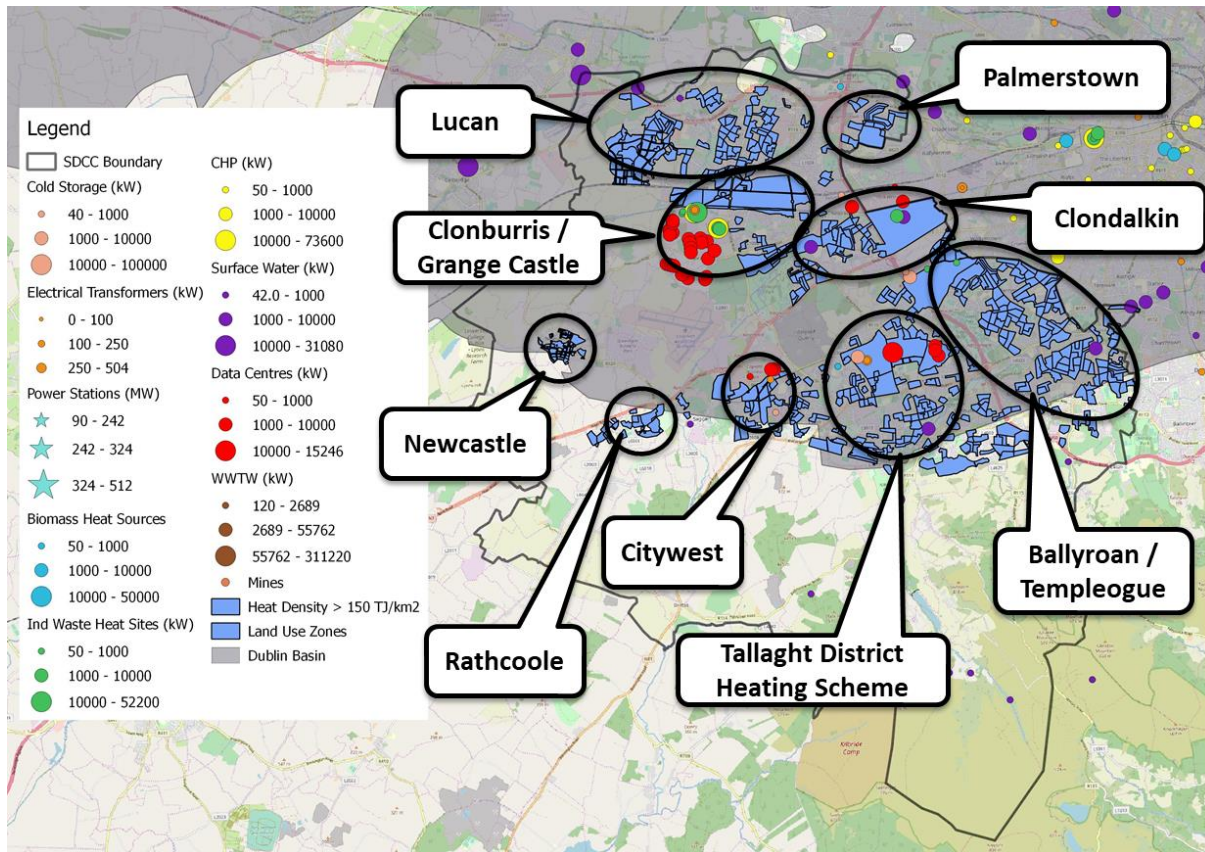



Figure 23: Opportunity Areas Identified - Based on SEDA Heat Demand (>150 TJ/km²), Relevant Land Use (SDZ, REGEN & RES-N) and Heat Source Locations

Opportunity Areas Ranked Based on High-level Assessment

The opportunity areas that were identified then underwent a high-level assessment and were ranked based on heat demand density of both existing and planned loads and the synergy between heat demand and heat supply. The purpose of this ranking was to develop a prioritised pipeline of potential projects to be taken forward to feasibility stage. The results of this ranking exercise are set out in the table below.

Table 5: Opportunity Area Rankings & Reasoning

Rank	Name	Comment
1	Clonburriss / Grange Castle	<p>Good level of heat demand provided by new, high density residential units (60 dwellings per hectare with approximately 60% of these being apartments) and the 55,500m² of commercial, retail and community floor space within the boundary area shown in purple below. These new buildings are also required to be future-proofed for connection to a DH network and will help avoid any added cost for retrofitting.</p>  <p>To the south-west of the Clonburriss SDZ is Grange Castle, which has an abundance of heat sources in areas closest to the Clonburriss SDZ, including high-grade waste heat from a large dual-fuel CHP plant and lower grade waste heat sources from multiple data centres in the area.</p> <p>It should also be noted that there is an area zoned as new residential to the east of Grange Castle, directly to the south-east of the junction between Nangor Road and Grange Castle Road. If this development is of high enough density and has some good use diversity, it could represent a good opportunity to utilise more of the Grange Castle heat loads and continue the network back towards Clondalkin.</p>
2	Clondalkin	<p>Clondalkin has a number of adjacent CSO “small areas”, with high heat density generally in the 170 – 225 TJ/km² range in areas to the west of the M50. This westerly area also has two main heat sources nearby: surface water, in the form of the River Cammock and data centre waste heat. However, the data centre would require a canal crossing to reach the demands.</p> <p>The area to the east of the M50 has a heat density of 205 TJ/km² and has two centrally-located potential heat sources: surface water in the form of the River Cammock, and industrial waste heat from R.A. Bailey & Co. (Diageo), Nangor House.</p>

3	Ballymount / Templeogue	<p>This area has numerous adjacent CSO “small areas”, which have a heat demand in excess of 150 TJ/km². It also incorporates a regeneration area at its northern end, which could provide further head demand and/or heat sources.</p> <p>In terms of heat sources, three have been identified towards the north of this opportunity area in the form of a potential heat offtake from a cold storage facility and two industrial waste heat sources, which are currently sending some of their waste heat to drain. Towards the southern end of this area, there is a surface water heat source (Owendohar River).</p>
4	Palmerstown	<p>The CSO small areas to the south have a high heat density generally in excess of 200 TJ/km². These areas are also closest to the Cherry Orchard Hospital and Wheatfield Prison, both of which have very large heating loads. Cherry Orchard Industrial Estate is also home to a regeneration area, which could provide further heat demand in the future.</p> <p>There were no existing heat sources identified in the direct vicinity. However, given that the hospital and/or prison will also have a significant electrical load this potential scheme may be best served by a CHP engine. There may also be potential for a geothermal-based supply given the presence of the Dublin Basin and plenty of land area as a location for drilling a set of doublets.</p>
5	Lucan	<p>Lucan has a number of high-density heat demand clusters. The cluster to the west of this region also has a significant area that has been earmarked by SDCC as a strategic development zone. Such an area could represent a considerable opportunity if the right dwelling density and diversity of building use was adopted.</p> <p>The River Liffey provides a heat source to the north of the region. The more southern areas could potentially be supplied through a geothermal-based solution if a suitable site for a doublet becomes available, or by CHP if an on-site electrical load of the required magnitude can be identified.</p>
6	Citywest	<p>This opportunity area has a large proportion allocated for new residential developments, with some existing high-density loads towards the south. If these new developments provide dwellings in high enough density and with good diversity, this could represent a strong future opportunity for DH. This is further enhanced by the presence of a number of data centre waste heat and cold storage heat sources.</p> <p>If the sources identified are found not to be viable, then there is also the potential to further investigate geothermal supply in this area, as it is located on the Dublin Basin.</p>

7	Rathcoole	<p>Rathcoole has good heat demand density (>150 TJ/km²) helped by some high-density residential developments near Elm Walk and Eaton Way and is also home to a nursing home along Stoney Lane. These loads could potentially form the basis of a DH system in the area, which could be further enhanced by the adoption of higher-density residential developments within the area to the south, which is zoned for new residential.</p> <p>There are currently no identified heat sources in the area, which may favour CHP as a method of supplying heat. However, an on-site electrical demand would need to be identified to make this a viable option.</p>
8	Newcastle	<p>The necessary heat demand for a DH scheme in this area would require a high-density development to be proposed for this area, which has been zoned for new residential.</p> <p>There may be potential for geothermal-based supply given the presence of the Dublin Basin and plenty of land area to choose the location of a doublet. Alternatively, a CHP-based solution could be considered; however, an on-site electrical demand would need to be identified to make this a viable option.</p>

5. Techno-Economic Analysis

5.1 The Importance of Performing a Techno-Economic Analysis

Undertaking a comprehensive techno-economic analysis (TEA) is crucial to understanding the project's technical feasibility and financial viability and therefore will act as the main evidence base for informing the local authorities' decision to take the project forward for development.

The TEA looks at the impact of technical design decisions (e.g. the sizing of plant and pipework) on the business case for the project. The TEA should help ensure that the scheme is optimised to deliver the required level of heat at the lowest cost and with the lowest CO₂ emissions. This requires the development of an energy system and financial model to appraise the various technology and design options over the lifetime of the project. Development of such models requires technical expertise regarding the limits and performance characteristics of the various elements of the district heating system such as the heating plant (heat pumps, boilers, CHP, EfW etc.), thermal storage, network (hydraulics and heat losses) and pumping requirements and how these vary under certain temperature, pressure and load conditions. An example of a typical energy model output can be seen in the figure below. Another important consideration in optimising the system is the diversification of the heat load (i.e. the coincidence of heat demand between different customers) and this should be considered when sizing the plant.

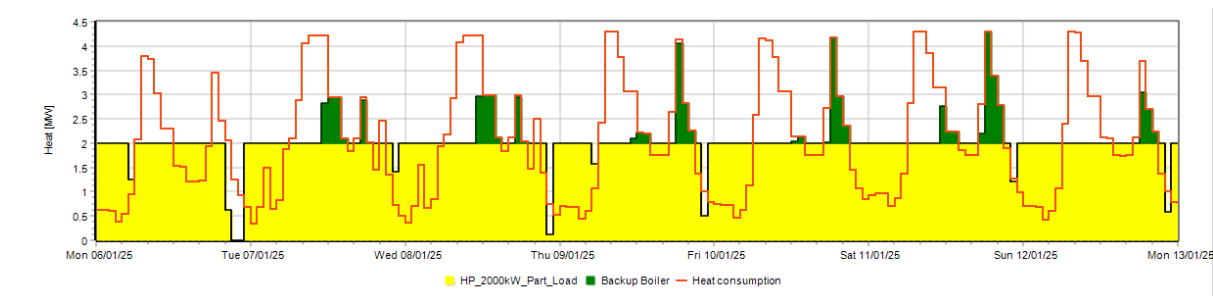

Figure 24: Hourly Plant Operation Profile from Energy Model - Example

The financial model will analyse capital expenditure (CAPEX), operational expenditure (OPEX), financing costs, revenue etc. over the lifetime of the project. It is also important that the modeller can quantify the cost implications associated with finding the shortest practical route for the network, installing pipes in soft rather than hard dig areas, and crossing other infrastructure (e.g. road, rail, waterways, other utilities). All these elements are then fed into the financial model to determine its viability and aid in its optimisation.

The financial model will generate outputs such as cash flows and the likely returns on investment for the various technology and design options over the project lifetime. In discounted cash flow models, a net present value (NPV) is calculated and this needs to be greater than zero, or the calculated internal rate of return (IRR) will need to achieve a particular hurdle rate in order for the project to be deemed investible. This hurdle rate would typically be determined by the investor; public sector investors such as local authorities will likely have lower hurdle rates than private investors, as their focus is more on the wider social, economic and environmental benefits of the scheme rather than profit margins. This model can also indicate the heat selling price that would

be required to achieve the necessary NPV, hurdle rate or payback and whether such a price would be considered acceptable to the heat customers.

5.2 Example Techno-Economic Analysis: Tallaght District Heating Scheme

Codema performed a district heating options appraisal for the Tallaght District Heating Scheme using detailed techno-economic energy system modelling, which incorporated leading Danish DH software energyPRO v.4.5. A detailed network sizing and route analysis was carried out using hydraulic modelling techniques with GIS software. The energy system design and modelling produced in this analysis was for the purpose of estimating the expected capital and operational costs of the proposed DH system as accurately as possible for the financial appraisal and is not the final system design. The final design of the system will be contracted to an ESCo as part of the proposed DBOM contract.

The system was modelled on an hourly basis using heat demand profiles, based on actual metered heat usage in buildings and monitoring data from buildings where available. For planned new builds, heat demands were modelled using the Dwelling Energy Assessment Procedure (DEAP) software, which is used to ensure compliance with the latest building energy regulations.

Hourly system modelling allows more accurate estimation of peak demands and therefore more accurate plant and thermal storage sizing. This allows the system model to prioritise the use of the lowest cost heat source in all hours. All network costs were based on UK experience of hard dig and soft dig conditions and compared to Irish costs where available. Previous studies have shown UK costs to be more aligned with Irish costs, and Scandinavian costs are found to be much lower than can be expected in Ireland, due to more competitive trenching costs rather than actual pipe costs. Irish supplier quotes for associated DH equipment were included where available, and where unavailable UK costs have been applied.

Low Temperature Versus a Medium or High Temperature Supply

There are two technical options available in terms of supplying the waste heat from the data centre for heating. The first is to design a low temperature DH network to circulate the warm water from the data centre at source temperature (~25°C), and boost to usable temperature at multiple individual heat pump substations at customer level. The second option is to design a medium/high temperature DH network to circulate hot water from a central energy centre on the data centre site which takes the waste heat and boosts it to a usable temperature (~70-90°C) via a heat pump. The pros and cons of each option are summarised in the table on the next page.

	Low Temperature & Distributed Heat Pumps	Medium/High Temperature & Centralised Heat Pumps
Pros	Lower network losses Temperature supply matched to customer demand Larger plastic pipes possible to use for transmission Easier to integrate other lower temp sources	Economies of scale Lower cost commercial electricity supply Potential SSRH support for large-scale heat pumps Smaller pipe sizes therefore smaller trenches Lower capital cost of network No site costs for the energy centre Lower pumping requirements Optimisation of HP with large-scale thermal storage Centralised equipment reduces maintenance costs
Cons	Larger pipe sizes therefore larger trenches Higher capital cost of network Space required for HP substations Cost of substation sites Maintenance of multiple substations vs energy centre Increased pumping requirements - larger volume of water On-site back-up boilers & storage	Electricity substation & connection costs Increased heat losses Network supply temp higher than required in new build

Table 6: Pros & Cons of Low vs Medium/High Temperature District Heating System

It can be seen in the table above that in the case of the TDHS, the pros of the medium/high temperature system outweigh those of the low temperature system, and vice versa on the cons of each system. The main influencing factors are the additional upfront capital costs of the low temperature network and the additional complications of acquiring land/space and building substations at each customer site when a centralised energy centre site is already available. The potential lower heat loss of a low temperature network does not justify the additional cost of the network in this case; as shown later, the losses of a well-designed medium/high temperature system of this size are negligible. The higher supply temperature to new builds is not a major issue as the majority of heat demand comes from existing buildings and require higher temperatures.

Network Sizing and Route Options

The distribution network typically represents the largest capital cost for a district heating scheme. The factors that influence the capital cost of the network are:

- The route the network takes – the shortest route, least road crossings and soft dig areas all reduce costs
- The type of pipework - material (steel, PE-X, etc.) construction (single, twin, etc.) and type of insulation (e.g. series 1, 2 or 3 polyurethane insulation) all affect the cost of the pipework
- The size of pipework – the larger the pipe diameter, the larger the pipe and trenches costs, and trenching costs make up the majority of network costs in hard dig areas

In order to estimate the capital costs of the network, Codema carried out a detailed technical options appraisal. Over 104 scenarios were modelled, and the results of this analysis with regard to the three main influencing factors listed above are set out in the next sections.

Route Options

Three different potential routes were examined to connect the customers identified. These routes were evaluated based on the ability to reduce capital costs, which are affected by the length, ground conditions and physical constraints (underground utilities, trees, road crossings, etc.) of each route.

Route 2, shown in the figure on the next page is the optimal route, representing an average lifetime cost saving of 10.8% and 13.8% compared with Route 1 and Route 3, respectively.



Figure 25: Resulting Preferred Network Route

Pipe Material

A variety of pipe types were analysed, examining the cost and performance impacts of different materials, construction and insulation types. The chart below shows the cost difference over a 40-year lifetime of the two different pipe construction types (single and twin) with varying levels of insulation. The results show the cost-optimal pipe is single bonded steel Conti pipe with series 3 polyurethane insulation for both the flow and return network. This may vary with any change in the cost of heat production.

Medium versus High Temperature Supply

A detailed cost-benefit analysis of the pipe network sizing over a 40-year lifetime examined designing the system to supply heat at 70°C flow temperature versus a system designed for a 90°C flow temperature during peak periods. The results show designing for a 90°C flow temperature for peak periods is preferable, as it reduces the pipe sizes required and therefore the cost of the network, as well as reducing the heat losses during normal hours? (heat pump operation).

Plant Sizing

The plant required to supply heat to the DH customers must be sized in order to estimate the capital costs of the energy centre. Correct sizing of the plant is important in terms of both up-front capital costs as well as ongoing operational costs. A detailed model of the TDHS was created and a cost-benefit analysis was carried out

in order to appropriately size the heating and thermal storage equipment required. The modelled operation is optimised based on the net production cost of generating heat, meaning the heat plant with the lowest cost production is prioritised, and its output maximised, where possible. An example of the production output under one of the scenarios modelled is shown in the figure below.

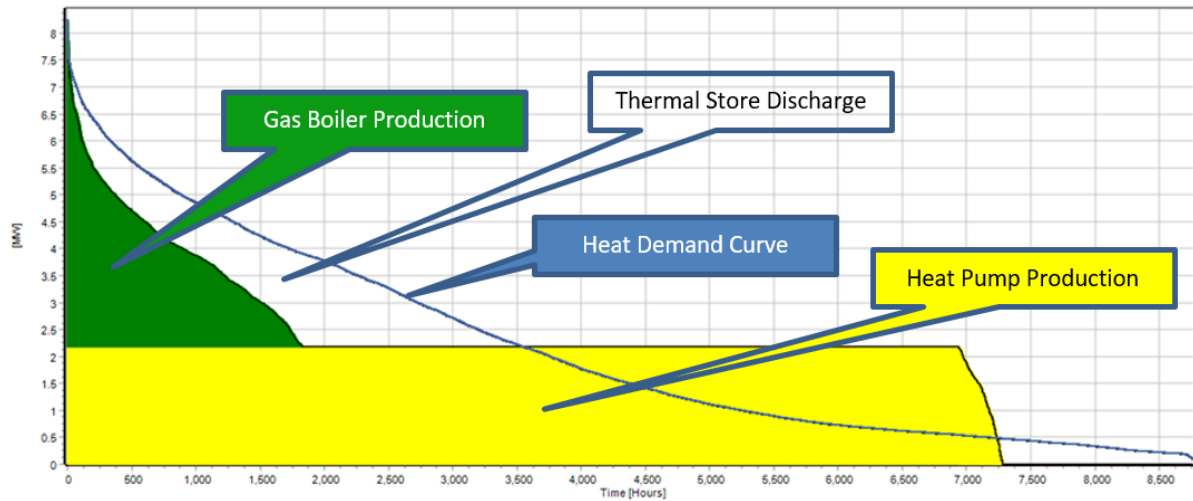

Figure 26: Example of Plant Size Modelling – Heat Production & Duration Curve

Financial Analysis

The results of the above techno-economic analysis were used to populate the TDHS’s financial model. This model was used to calculate the key financial figures (NPV, IRR, payback, etc.) to assess the project’s financial viability and its sensitivity to changes in heat price, phasing, demand, capital cost, connection charges, funding costs, etc. Factors that are deemed critical to achieving the required hurdle rates were also highlighted and included in the project risk register.

6. Stakeholder Engagement – Who to Involve in Your DH Project and When

6.1 Introduction to Stakeholder Engagement

Stakeholder identification and engagement plays a vital role in the delivery of a district heating scheme. Stakeholder engagement can often be neglected, with priority being given to the technical aspects of a project. However, building relationships and engaging in an ongoing, open dialogue with potential customers and other key stakeholders is crucial when it comes to ascertaining the viability and eventually delivering a DH project. This engagement process allows more accurate information to be obtained regarding heat loads, each party's key drivers (environmental, legal, economic, etc.), potential customer heating systems, level of interest / commitment to the project, all of which will inform key decisions.

6.2 Effective Stakeholder Engagement

This section of the report sets out the steps to take in order to achieve effective stakeholder engagement. These steps include identifying the relevant stakeholders, prioritising your stakeholder list, understanding stakeholder drivers and barriers, and adopting the most effective methods and timing of the engagement / collaboration.

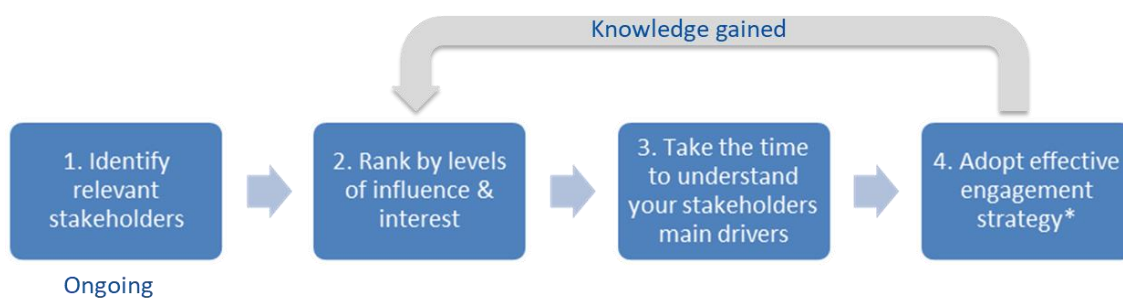

*The frequency, timing and type of communication will vary based on stakeholders' role and ranking

1. Identifying the Relevant Stakeholders

The first step is to identify the stakeholders relevant to your project. This will include anyone who might contribute to, has an interest in, or may be affected by the development of your DH scheme. This might include some of the following the local authority (e.g. city or county council), local energy agency, planning bodies, finance/investors, procurement, legal, analysts, environmental body, developer(s), project team, SEAI, highways, customers (businesses and residents), heat sources (Industrial, ESCo etc.), consultancy, ESCo, DHCo, media/communications.

It is important to note that **you may not know all the relevant stakeholders from the start of the project and that this list is a live document, which will be updated throughout the project** as more information becomes available and a greater understanding of the drivers and barriers is achieved. **A good starting point for developing your initial list of stakeholders is to think about the roles that will need to be filled in order for**

your district heating scheme to be delivered and put relevant stakeholders' names against each role. These roles can be categorised²³ as follows:

1. Promotion (driving delivery of project)
2. Customer (purchasing heat from network)
3. Governance (prescribing objectives, rules and policies)
4. Regulation (consumer protection)
5. Funding (arranging finance)
6. Asset ownership (owns the physical assets such as generation assets, network, etc.)
7. Development of property (constructing and maintaining buildings connected)
8. Land ownership (grant access for installation and maintenance)
9. Landlordship (landlord of connected buildings ensuring occupiers connected and secondary or tertiary heating system maintained)
10. Installation (design and installation of DH system, which may include the energy centre, network and heat substations or HIUs)
11. Operation (operates and maintains heat network)
12. Heat sales (metering, billing and customer service)
13. Supplier of last resort (provide backup supply of heat to customers)

It is important to note that multiple stakeholders may fit into one role category (e.g. multiple stakeholders as customers) and also that one stakeholder may perform multiple roles (e.g. an ESCo might fund, install, operate and sell heat). In cases where you have internal stakeholders within your organisation or initial project team, it would be of benefit to sit down together to develop as broad a list of further stakeholders as possible and share any contact details you might have. Directly contacting stakeholders that you already know and have a good relationship with will generally result in a far greater degree of engagement.

2. Understanding Stakeholder Drivers and Barriers

Stakeholder drivers for developing a district heating scheme should be identified and recorded at an early stage in the process. These drivers will help shape the project objectives and can outline the role each party will need to play in delivering these key objectives. The list on the next page highlights some of the main drivers behind connecting to and developing a DH scheme and how they might relate to certain stakeholders. This list is based on learnings from previous stakeholder engagement and supplemented by additional drivers identified in the strategic and commercial case guide²⁴ published by the Department of Business, Energy and Industrial Strategy (BEIS) in the UK.

²³ BEIS Heat Network Detailed Project Development Resource: Guidance on Strategic and Commercial Case (2016)

²⁴ BEIS Heat Network Detailed Project Development Resource: Guidance on Strategic and Commercial Case, Appendix C (2016)

Table 7: Drivers for the Development of District Heating - Examples

Area	Drivers	Local Authority	Developer	Customer
Environmental	Carbon emissions reduction	✓	✓	✓
	Increasing renewable energy share of the heating fuel mix	✓	✓	✓
	Air quality improvement	✓		
	Reduced noise	✓	✓	✓
Economic and financial	Reducing local authority energy costs	✓		
	Job creation and stimulation of the local economy	✓		
	Sustainable source of revenue for the local authority	✓		
	Contract or service value for money	✓	✓	✓
	Space savings in connected buildings	✓	✓	✓
	Cost-effective compliance with building regulations	✓	✓	✓
	Increasing regional competitiveness – attracting industry with low-carbon, low-cost heat	✓		
	Energy tourism	✓		
Technical	Trench sharing savings	✓	✓	
	Resolving performance issues with existing building heating systems	✓	✓	✓
	Energy security and resilience	✓	✓	✓
	System reliability and maintainability	✓	✓	✓
Social	Innovation	✓	✓	✓
	Alleviating fuel poverty	✓		✓
	Reducing energy costs to customers	✓		✓
	Customer satisfaction (improved comfort, control, simple billing, customer service)	✓		✓
	Regeneration of housing stock	✓		✓
Political	Protection of vulnerable customers	✓		✓
	Local authority capacity and skills development	✓		
	Compliance with national or regional policies	✓	✓	✓
Legal	Reputation	✓	✓	✓
	Compliance with regulations	✓	✓	✓
	Compliance with planning policy	✓	✓	✓
Circumstantial	Compliance with metering/billing regulations	✓	✓	✓
	Planned new development (identified as a potential anchor load for an area-wide network)	✓		
	Capital funding becomes available	✓	✓	✓
	Existing building or estate heating system reaching the end of its operational life	✓	✓	✓
	Local heat source (identified or planned, which could supply heat to buildings via a heat network)	✓		✓

To get a deeper understanding of the relative importance of these key drivers, ask the stakeholders to rank the above objectives on a scale of 1 to 10, with 10 being the highest priority. These scores can be represented visually

in the form of a radar chart to highlight the key objectives of the project for multiple stakeholders. This will help to communicate the most relevant information to each stakeholder. In the example in the figures below, we can see that the main drivers for the local authority are in the environmental area, specifically the reduction of carbon emissions, improving air quality and increasing the use of renewable energy for heating.

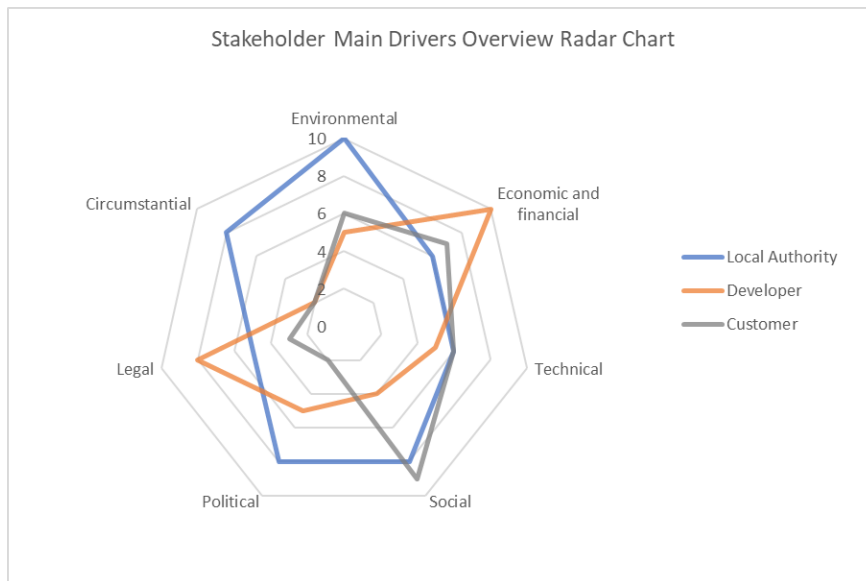

Figure 27: Stakeholder Main Objectives Overview - Sample Radar Chart

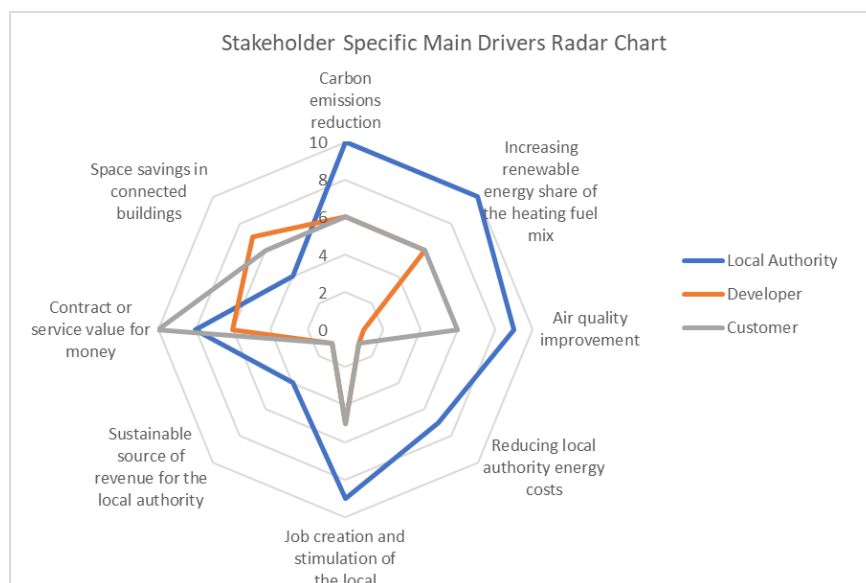

Figure 28: Specific Stakeholder Objectives - Sample Radar Chart

3. Prioritise stakeholders

The prioritisation of stakeholders is important in order to identify where best to focus your engagement efforts. One way of prioritising stakeholders is to rank each one on the level of influence they could have on the project and also on the level of interest and enthusiasm they display for being involved; this will allow you to plot their position (in quadrant A, B, C or D) on an impact-interest grid (see example grid on the next page) and help

determine the type and frequency of the ongoing engagement required based on this position. The initial ranking of stakeholders will be carried out based on your own knowledge and assumptions regarding heat demand estimates, waste heat availability, ownership (e.g. publicly owned) and proximity to the proposed network; this may be subject to change as more information becomes available following more in-depth discussions with each stakeholder.

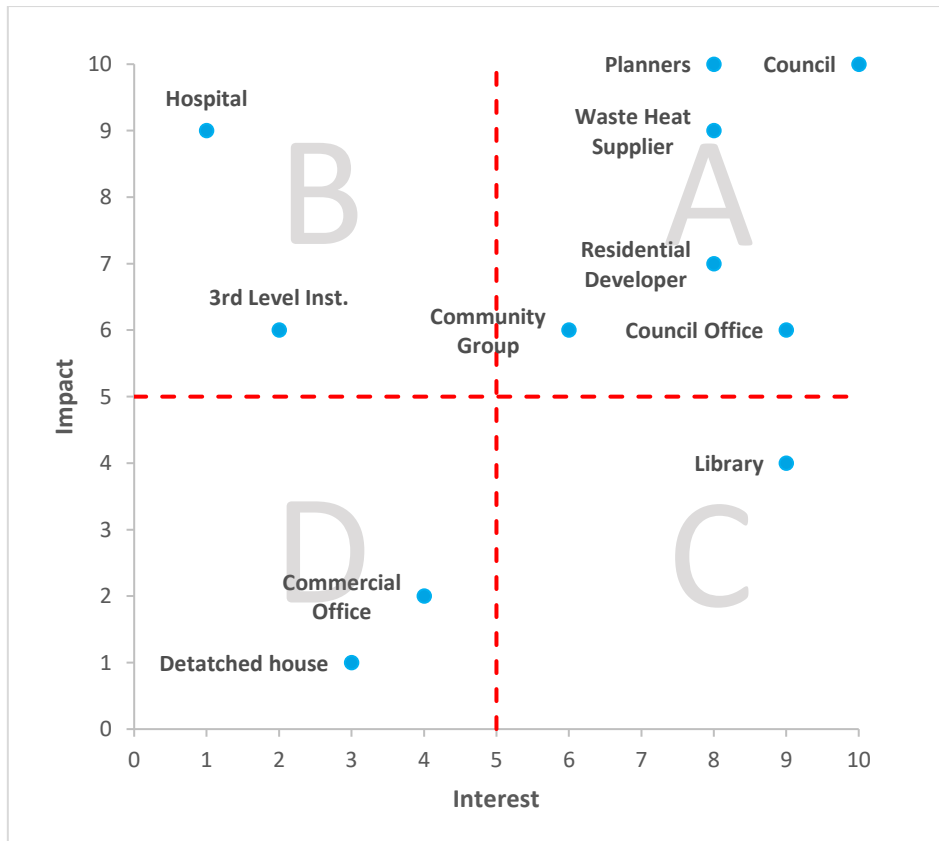

Figure 29: Indicative Impact - Interest Grid

Stakeholders that fall within the “A” section of the graph have both a significant interest and potential impact on the project, making them crucial to the success of the project. It is therefore key that they have a strong understanding of the project and can actively contribute to its development. This should involve two-way engagement (face-to-face meetings, emails, phone calls), joint learning, decision making and actions.

If a stakeholder falls within the “B” section of the graph, i.e. could have a high impact but has a lower interest in the project - perhaps a stakeholder who does not want to be actively involved in the project but may have access to information that could greatly impact the viability of your project – they should be encouraged to share their views. This can be done by sharing project progress updates and asking for comment. This will involve two-way engagement within a more limited area of responsibility.

Stakeholders which are positioned in section “C”, of the graph which have high levels of interest but a lower impact on the project may not initially have a key role in the project’s success but should be kept informed about the project as it progresses, as they could potentially have a larger impact at a later date (e.g. might be a customer who end up expanding their premises and significantly increase their heat demand which could act as an anchor load) and perform a key role within the project.

Stakeholders that fall within the “D” section of the graph, where they have low interest levels and low impact on the project, are the least critical group to the success of the project; however, it is still important to keep these stakeholders informed as there may be unknown or unexpected supporters within this group whose status may change as the project moves forward or may influence other stakeholders. This will be done in the form of one-way engagement (e.g. brochures, webpage, email, open consultation).

4. Effective Engagement

It is important to tailor your engagement methods to communicate as effectively as possible with each stakeholder and provide the most relevant information to highlight the most applicable benefits, address any concerns and show your understanding of the stakeholders’ main drivers (motivators and barriers). This approach, along with ensuring the stakeholders have the opportunity to give their perspective in every interaction, will help keep levels of interest high and lines of communication open, leading to greater collaboration and cooperation.

Your first engagement with all stakeholders should give a brief description of what district heating is and a description of your project and its objectives; this will help to clarify your project and help clarify what district heating is and how it operates. Where possible, this initial engagement should be carried out by a team member who has an existing good relationship with the stakeholder in order to build trust in the project. The potential benefits to the stakeholder of connecting to the DH system should also be highlighted at this point; the great thing about DH is that it has a wide range of potential benefits that are applicable to many stakeholders (see Table 7 above for some examples). Choose the benefits that are most applicable to the stakeholder and how your project can address any perceived concerns the stakeholder may have.

TIP: It is recommended that stakeholders are contacted via both email (to give the brief description of the scheme which can be shared within their organisation) and phone. It is a lot easier to gauge interest and have a more in-depth discussion over the phone if the stakeholder has any questions regarding how the system works, its benefit to them, etc.

It is also important that you state how the stakeholder can get involved in the project and the role they could play in developing the project (e.g. by providing information such as heat demand data or providing support for the project via a written statement of support) that would allow a greater understanding of the feasibility of the proposed scheme. It is important to organise further follow-up meetings with key stakeholders in order to keep the project details up-to-date and to share how the project is progressing.

The table on the next page gives an example of some of the useful information that may be provided by certain stakeholders to help progress the DH project. Note that this is not an exhaustive list and there may be other information also contribute towards the project.

Table 8: Possible Information that could be Requested from Stakeholders

Stakeholder	Useful Information
<p>Local Authority</p>	<ul style="list-style-type: none"> • Local area plan and location of development zones • Details of planning policy and how it facilitates district heating • Drawings or GIS files showing barriers to DH installation (existing utilities, infrastructure, environmentally sensitive areas, heritage sites) • Location, type and floor area of existing buildings • Location of publicly-owned sites
<p>Developer</p>	<ul style="list-style-type: none"> • Details of planning permission • Development phasing schedule (development quantum and timescale) • Development massing – location within the site of various buildings of different use type • Heating system details (planned system type and design temperatures) • Heat demand figures (BER, benchmarked, thermo-dynamic models) • Letter of support • Site investigation report – detailing ground conditions
<p>Potential Customer</p>	<ul style="list-style-type: none"> • Heating plant details (size, age, fuel used, etc.) • Energy bills and metered readings if available • Heating system details (system type and temperatures) • Details of planned refurbishment works (boiler replacement, fabric upgrades, etc.) • Letter of support

When to Involve the Relevant Stakeholders

Different stakeholders will have varying levels of input at different stages in the project. The figure below gives a general outline of the level of input from the main stakeholder groups through the seven main project stages used in the CIBSE heat networks code of practice. This will help guide the level of communication required from each stakeholder at each stage of the project.

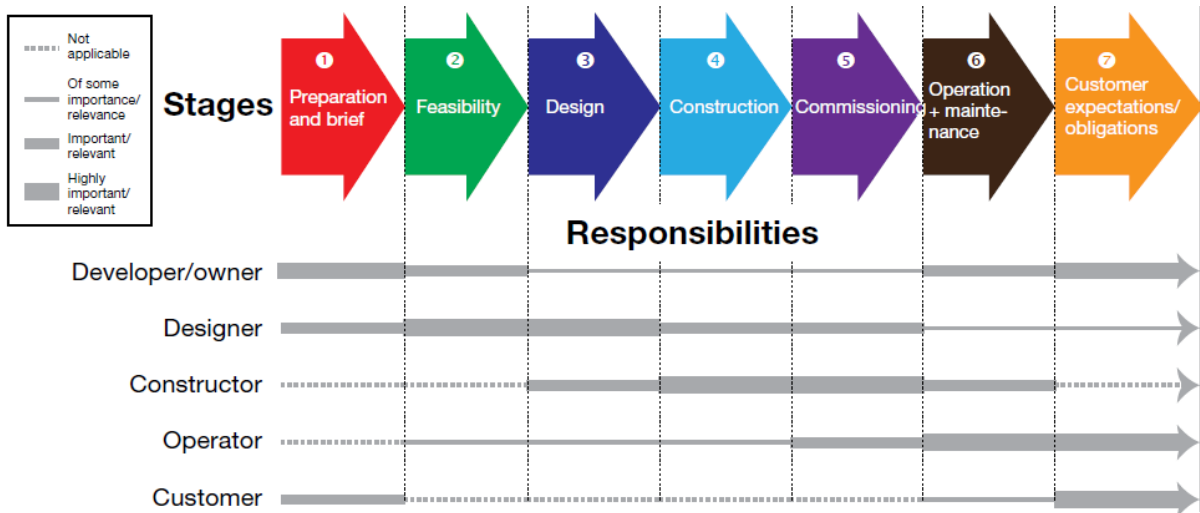

Figure 30: Stakeholder Input Graph (source: CIBSE Heat Networks Code of Practice)

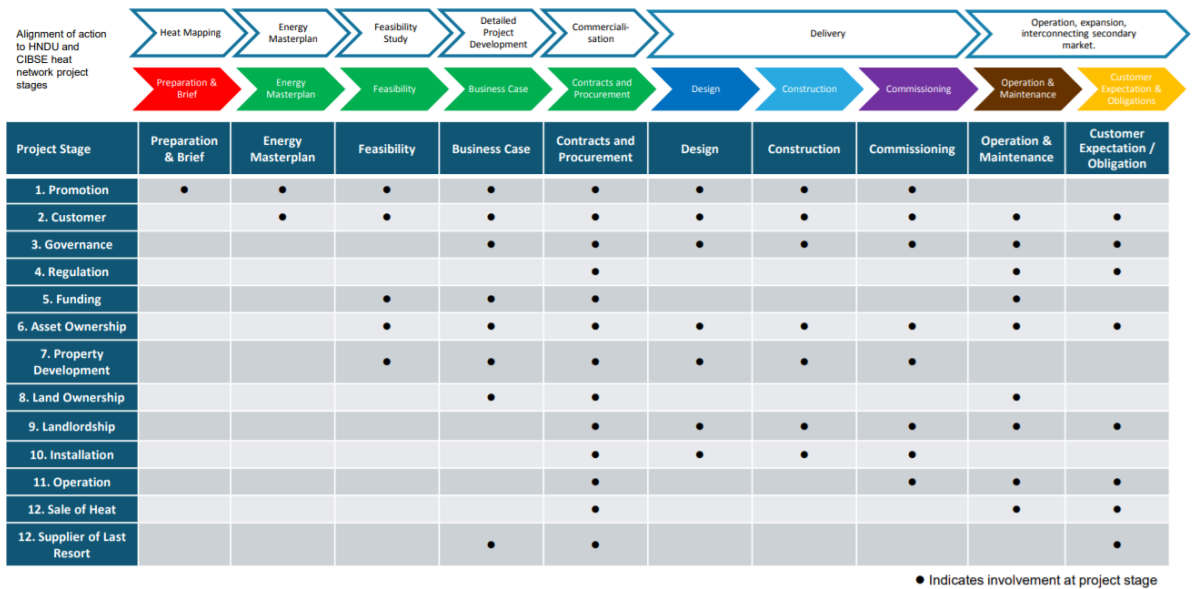

Figure 31: Stakeholder Involvement at Project Stage Graph, Source: BEIS Heat Network Detailed Project Development Resource: Guidance on Strategic and Commercial Case (2016)

7. Information to be Provided to Developers

This section of the report discusses the information that developers may be interested in regarding district heating. This information is based on discussions with developers involved in the TDHS pilot project.

7.1 Benefits of District Heating

Given that district heating is a relatively new technology in Ireland, the many benefits may not be known to developers interested in connecting to your district heating scheme. The list below indicates some of the potential benefits for developers of connecting to a district heating network.

TDHS: In the case of the TDHS project, one of the most attractive benefits to the developer was the cost-effective compliance with the new Part L building regulations when compared with the alternative case of supplying each residential dwelling with an air-source heat pump.

- Carbon emissions reduction
- Increasing renewable energy share of the heating fuel mix
- Contract or service value for money
- Space savings in connected buildings – heating plant such as boilers replaced by much smaller HEX
- Cost-effective compliance with building regulations (Part L) – Using a cost comparison with alternative compliant technologies
- Trench sharing savings
- Energy security and resilience
- System reliability and maintainability
- Reducing energy costs to customers
- Customer satisfaction (improved comfort, control, simple billing, customer service)
- Compliance with national or regional policies e.g. SDCC planning policy 6 which supports the development of low-carbon district heating networks
- Enhanced reputation for providing efficient, low-cost, low-carbon heating

7.2 Trench Sizes Required for DH Network

Trench sizes will vary depending on the size of pipe. For general guidelines on minimum soil cover requirements, distance between flow and return pipes, minimum depth of friction material under the pipes, etc. the Logstor Design Manual²⁵ or similar manufacturer guidance should be referenced. The actual trench sizes will be determined at the design stage of the DH project.

²⁵ <https://www.logstor.com/media/5342/design-201512a.pdf>

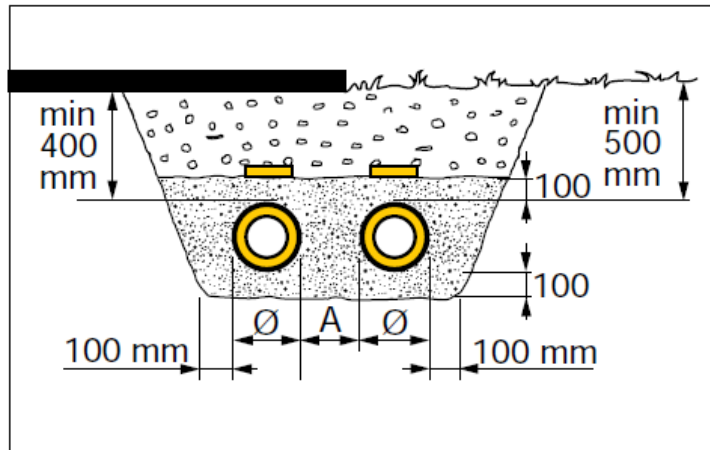

Figure 32: Indicative Trench Dimensions (source: Logstor Design Manual)

7.3 Wayleave Requirements for DH Network

Developers are interested to know the level of land-take required for the DH wayleave and how this might impact on their demolition, construction and landscaping works. It is assumed that where the DH pipes are located on private land, a Deed of Grant of Easement (similar to those used for water pipes) should be set out in the connection agreement by the land owner to incorporate a protected strip of land of specified width either side of the pipe to ensure the ability of the SDDH Co. to access the pipes. The width of the strip should allow access for the installation and repair of the pipework; 200mm clearance on either side of the pipe is assumed to be sufficient for this based on experiences in other European countries²⁶. This strip will run the full length of the pipe and should be highlighted on a Property Registration Authority compliant map and approved by the SDDH Co. prior to execution of the Deed.

7.4 Allowable Distances Between DH Pipes and Other Services

One of the main queries from developers surrounds the space requirement of other utilities to prevent any operational risks. In the absence of Irish specific standards, the TDHS scheme currently assumes the best-practice Danish standards²⁷ for minimum distances (see table on the next page). The purpose of the distances is to protect other service pipes and cables from mainly the impact of heat from the DH pipes that may add to the heat already produced from utilities, such as power cables. District heating pipes may also affect gas mains where heating may reduce the normal flow in the gas pipe.

²⁶ Based on discussions with DBDH

²⁷ DS 475 (2012)

Table 9: Allowable Distances Between DH Pipes and Other Utilities

Minimum distances from Danish Standard DS 475 (2012)

		Distance m	District Heating Pipes d > 400 mm	District Heating Pipes d < 400 mm
Gas transmission pipes	5-8 MPa	C	0.5	0.5
		P	5.0	5.0
Gas transmission pipes	1-4 MPa	C	0.5	0.5
		P	1.0	1.0
Gas distribution pipes - PEM		C	1.0	1.0
		P	2.0	2.0
Gas distribution pipes - not PEM		C	0.1	0.1
		P	0.3	0.3
Electric power supply	1kV<U<30kV	C	0.3	0.2
		P	1.0	1.0
Electric power supply	U<1kV	C	0.2	0.1
		P	1.0	0.5
Drains	concrete etc.	C	0.2	0.2
		P	0.3	0.3
Drains	plastic	C	0.1	0.1
		P	0.3	0.3
Field drains < 160 mm		C	0.1	0.1
		P	0.3	0.3
Water pipes	plastic	C	0.1	0.1
		P	1.0	1.0
Water pipes	cast iron/ steel	C	0.2	0.2
		P	1.0	0.7

'C' – crossing pipes/cables

'P' – parallel pipes/cables

7.5 The Importance of Secondary-Side Pipework Heat Losses

The developer will typically install the secondary-side internal pipework in the connected buildings (connecting to radiators, apartment HIUs, etc.). Limiting secondary-side heat losses results in a more efficient system and prevents any issues with overheating. Reducing pipe heat losses within the building is especially important in new well-insulated, more air-tight buildings where overheating potential is much higher. Two of the main methods of limiting internal heat losses are to minimise the length and diameter of the pipework and to ensure adequate insulation is used on all pipework and fittings. It is recommended that the pipework heat losses/unwanted internal heat gains should not exceed 10% of the heat consumption in accordance with best practice²⁸.

The table on the next page provides guidance on the required insulation thickness to achieve best practice in terms of internal heat loss from internal distribution to pipework in buildings.

²⁸ Heat Networks Code of Practice

Table 10: Internal Pipework Insulation Requirements - Best Practice (Source: Connecting to the Bristol Heat Network Part 2, Energy Service, Bristol City Council 2018)

Pipe Size NB (mm)	Thickness of Insulation (mm)			
	BS5422 level Mineral Wool	Calculated level Mineral Wool	ECA Y50 level Phenolic Foam	Calculated level Phenolic Foam
20	30	50	15	25
25	35	50	20	25
32	35	60	20	30
40	35	60	20	30
50	40	60	20	30
65	40	60	25	35

To minimise the length of pipework (and associated heat losses) in apartment blocks, a greater number of vertical risers should be used to minimise the horizontal runs of pipe in corridors, as shown in the figure below.

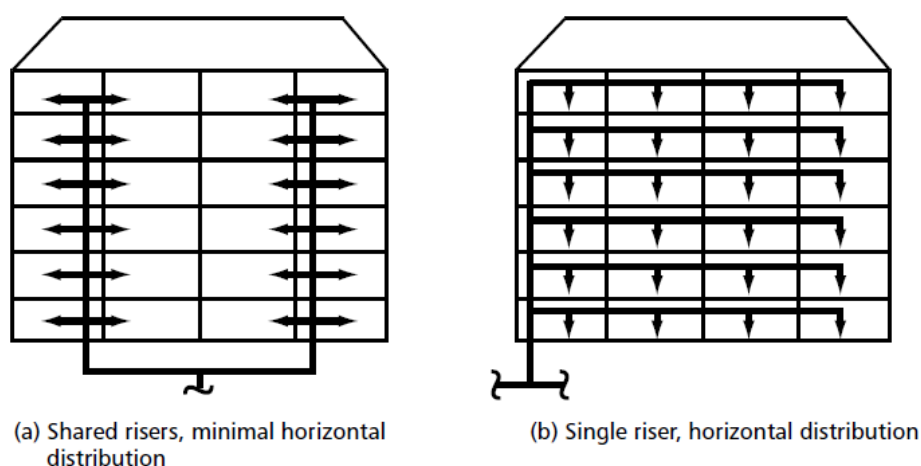

Figure 33: Shared Riser Diagram (Source: CIBSE Heat Networks Code of Practice)

7.6 Maintenance Access Requirements

The district heating company / ESCo will maintain the DH pipe network, typically up to the customers' heating substation (heat exchanger). The secondary pipework inside the building can be maintained by the developer/facilities manager, similar to a centralised system; however, this work could be carried out by the ESCo subject to agreement and provision of access.

The developer should provide access to the supplier during the assembly and installation period for delivery, positioning and installation of the equipment. Following completion of the works, the developer should allow the supplier unlimited access to the supplier infrastructure for commissioning, maintenance and operational purposes. The pipe itself will require little or no maintenance as this will be carried out in the energy centre by measuring water quality and dosing. Thermal imaging may be carried out if any leak is detected in the system to pinpoint areas that might require repairs; this is likely to be very rare and won't require any special access other than providing adequate space for digging. The main access requirement for maintenance of the network will

be at the substations, valves (via valve pits where necessary), filters and compression compensation points (if applicable).

7.7 Provisions to be Made for Connection to DH Network – Developments within Opportunity Areas

One of the key challenges in connecting to a DH network is the timing between the delivery of a new network and the completion of the new development. If the network is delivered early, its viability may be affected by delays in customers connecting. If the network is delivered late, developments may need to use temporary alternative heat supply sources.

In the case where there is a high degree of certainty that a DH network will be developed but will not reach the new development until some years after the development is completed, the development should be designed to connect to the DH network from the beginning i.e. smaller plant room to accommodate DH substation. Heat could be provided by temporary local heating plant.

Where developments are in areas identified as feasible for DH but currently have no firm plans to develop a network, developers should future-proof buildings for connection to a DH network. This should include designing a centralised heating system for the building where tees and isolation valves are installed on the main heating header to allow for a connection to a future DH heat exchanger. The plant room should also include space for this heat exchanger or alternatively assume that the initial heating plant be removed when the connection is made to the DH network. However, the replacement option may cause more disruption to supply. The building fabric should also be designed to easily incorporate the pipe connection to the DH network and external buried pipework routes on site should be safeguarded for future installation of pipework.

7.8 Contract for the Supply of Heat and Heads of Terms

A service contract is to be agreed with the buildings' facilities management to supply heat from the DH network. As with similar services (gas and electricity) the Multi-Unit Developments (MUD) Act 2011 requires that all fixed period service contracts do not exceed three years. This heat supply agreement will cover items such as the roles and responsibilities of each party, payment, continuity of service, interruptions to supply, ownership, access requirements, termination, etc. More in-depth guidance on what should be considered when developing a heat supply agreement can be found in the "Guidance on Development of Heat Supply Agreements for District Heating schemes" report²⁹ developed by Scottish Futures Trust.

As district heating systems require significant up-front investment, it is important to have assurances that the required level of heat demand (customers) will connect to the network to make the system financially viable. In order to mitigate the risk of customers not connecting once installation of the network has begun, it is vital that a Heads of Terms (HoT) agreement be signed between the DH company and the key customers. A HoT agreement broadly outlines the terms of the full heat supply agreement and acts as evidence of serious intent by the customer to connect to the network but does not legally compel the parties to conclude the deal on those terms or even at all. Template Heads of Terms agreements can be found on the website³⁰ of the Department for Business, Energy & Industrial Strategy in the UK.

²⁹ Guidance on development of Heat Supply Agreements for District Heating schemes, Scottish Futures Trust (2018) <http://www.districtheatingscotland.com/wp-content/uploads/2018/02/HSA-guidance-final-Feb-18.pdf>

³⁰ <https://www.gov.uk/government/publications/heat-network-detailed-project-development>

7.9 Developer Contribution / Cost of Connection

The DH distribution pipe work (i.e. the pipe that branches off the transmission main and feeds the substations) and possibly the substations plus the added capacity required in the energy centre and (if applicable) transmission main should be provided by the developer in the form of a connection fee. The developer may also be asked to provide a contribution to reflect a proportion of the capital costs saved when compared with the alternative case. The alternative case is likely to be individual air-source heat pumps for new residential developments.

7.10 What Disruption to Existing Buildings Could be Caused if Connecting to DH?

As with all refurbishment works, when looking to connect an existing development to a DH there will be some disruption. Luckily with DH this disruption is minimal. There will be disruption within the apartment block as the infrastructure (pipework and HIUs) to connect each block to the network is installed. The time taken to do this will depend on the complexity of the job. It is estimated³¹ that it would take one or two days to install the heat interface unit and any necessary pipework within the flat itself. For apartments with electric heating, the replacement of the electric storage heaters with a wet heating distribution system would take around three days. It has been estimated³² that a full retrofit could be done within a week, if the work was well coordinated and ran smoothly.

7.11 Retrofitting Older Buildings for Connection to 4th Generation District Heating

The Guide on Retrofitting Buildings for 4DHC³³ has been prepared as part of the HeatNet NWE project and is aimed at helping stakeholders across NWE developing district heating projects to overcome barriers to implementing 4DHC solutions in existing buildings that are undergoing retrofitting. This guide outlines the key advantages and disadvantages of connecting buildings to 4DHC rather than other individual heating solutions and a cost comparison of these options, in order for stakeholders to understand why they should consider a DH connection when retrofitting a building.

The guide includes information on connection of energy efficient buildings to 4DHC, both from the perspective of the DH provider and the building owner. This includes details of identifying and connecting 4DHC developments, the thermal storage options available and the internal heat emitters required. The guide shows how buildings having high energy efficiency are suitable for 4DHC and how they can connect to existing higher temperature DH systems, and also how some existing buildings may not need much retrofitting to allow 4DHC supply.

The guide also outlines issues with low temperature supply like legionella risks, and how to optimise 4DHC connections to ensure best efficiencies are achieved. The support schemes for integrating 4DHC connections and energy efficiency upgrades in each of the partner countries in north-west Europe are summarised.

³¹ Retrofitting District Heating Systems, BioRegional (2012)

³² Retrofitting District Heating Systems, BioRegional (2012)

³³ Guide to Integrating 4DHC with Energy Efficiency Retrofitting, Codema (2019)

8. Planning Permission Requirements for Installing a Local Authority-Led District Heating System

8.1 Current Planning Requirements

There is some ambiguity regarding the planning requirements for the installation of district heating pipelines in Ireland. Given the lack of uptake in DH in Ireland in the past, the current planning guidance and legislation does not provide sufficient clarity on the issue. It is believed that DH pipes should be treated the same as any other underground pipe and be exempt from planning permission in the majority of circumstances, as outlined in the text from Section 4 of the Planning and Development Act³⁴ shown below.

“(g) development consisting of the carrying out by any local authority or statutory undertaker of any works for the purpose of inspecting, repairing, renewing, altering or removing any sewers, mains, pipes, cables, overhead wires, or other apparatus, including the excavation of any street or other land for that purpose;”.

In the case of the TDHS, South Dublin County Council completed a public consultation process known as a “Part 8”. This is discussed in the section below.

8.2 Example Planning: Tallaght District Heating Scheme Planning Permission (Part 8)

Developments by a local authority are subject to a public consultation process as set out in the Planning and Development Regulations, 2001 - 2015. This procedure requires that notice of the proposed development be given in the public press and that a site notice be erected. On completion of the display period and if any submissions or observations are received, a report is presented to the members of the Council. This report contains a list of the submissions along with a summary of the points made by them and the local authority's response. This report outlines whether or not it is proposed to proceed as originally planned or to proceed with a modified proposal.

³⁴ Office of the Attorney General (2000). Planning and Development Act 2000. Dublin: Irish Statute Book.

9. Business Model Options Available for a Local Authority-Led DH System

9.1 Choosing a Business Model

The type of business model adopted will be chosen based on the key objectives of the project (see Table 7 in section 6.2 for some indicative project objectives), the stakeholders attitude to risk, the level of control desired over the lifetime of the project, regulatory compliance requirements, access to finance and the desired rate of return on the investment.

9.2 Business Model Options

There are a multitude of business model arrangements available to local authorities interested in DH ranging from fully publicly owned, operated and maintained to fully privately owned, operated and maintained with varying degrees of public/private partnership options in between. These various options are discussed further in the HeatNet NWE Guide for Public Sector Organisations³⁵ and also in greater detail in a report by the International Energy Agency³⁶.



Table 11: Risk & Control Allocation Table, Source: Delivery Structure Risk Allocation and Roles (IEA Annex XI Final Report 2017)

Description	Risk Allocation	Local Authority
Entirely public sector led, funded, developed, operated and owned	Public sector retains all the risk	Public sector procures contracts for equipment purchase only. Procurement could be direct, or via a publicly owned arm's-length entity
Public sector led: entirely publicly funded, greater use of private-sector contractors	Private sector assumes design and construction risk, and possibly operational risk	Public sector procures turnkey asset delivery contract(s), possibly with maintenance and/or operation options
Public sector led, private sector invests/takes risk in some elements of the project	Private sector takes risk for discrete elements (e.g. generation assets)	As in option 2 but with increased private sector operational risk, and payment or investment at risk
Joint Venture (JV): public sector & private sector partners take equity stakes in a special purpose vehicle (SPV)	Risks shared through joint participation in JV vehicle/regulated by shareholders' agreement	Joint Venture: both parties investing and taking risk
Public funding to incentivise private sector activity	Public sector support only to economically unviable elements	Public sector makes capital contribution and/or offers heat/power off-take contracts
Private sector ownership with public sector providing a guarantee for parts of the project	Public sector underpins key project risks	Public sector guarantees demand or takes credit risk

³⁵ Developing District Heating in North-West Europe; A Guide for Public Sector Organisations (2019) http://guidetodistrictheating.eu/wp-content/uploads/2020/04/HeatNet-NWE_Business-Case-to-Public-Sector_District-Heating.pdf

³⁶ IEA Annex XI Final Report (2017)

Private sector ownership with public sector facilitating by granting land interests	Private sector takes all risk beyond early development stages	Public sector makes site available and grants lease/license/wayleaves
Totally private sector owned project	Private sector carries all the risks	Zero or minimal public-sector role (e.g. planning policy, stakeholder engagement)

 PUBLIC SECTOR MODEL	 PUBLIC/PRIVATE HYBRID SECTOR MODELS
<p>STRENGTHS</p> <ul style="list-style-type: none"> ~ Can access public sector financing ~ Revenue generation for municipality ~ Greater control on flexible development, tariffs and network growth ~ Can deliver aggregate demand and provide public sector anchor loads and reduce demand risk <p>WEAKNESSES</p> <ul style="list-style-type: none"> ~ Public body must carry technical and commercial risk ~ Longer public sector procurement process ~ Reduced access to equity funding ~ Lack of ring-fenced budget can create risk on internal department budgets 	<p>STRENGTHS</p> <ul style="list-style-type: none"> ~ Transfers more of the technical and commercial risk to the operator ~ Shorter private sector procurement may be possible ~ May be able to leverage third-party financing or can draw public sector financing <p>WEAKNESSES</p> <ul style="list-style-type: none"> ~ Reduced control from public partner in certain aspects ~ May need to provide higher rates of return which may result in higher tariffs and reduced flexibility ~ Possible early exit by partner may compromise project objectives ~ In concessions, liabilities may be consolidated into public sector accounts

Taken from the International Energy Agency Annex XI Report 2017

Figure 34: Business Model Strengths & Weaknesses for both Public and Public / Private Business Models (Source: HeatNet NWE Guide for Public Sector Organisations)

9.3 Example Business Model: Tallaght District Heating Scheme Preferred Business Model

SDCC needs to retain ownership of the network assets and a level of control over the system operations in the early stages if it is to secure the overarching project objectives and to ensure successful growth of the system. This must be balanced with the capacity of SDCC to carry out such functions and funding constraints. In order to ensure capacity is available, to increase in-house capabilities over time (and reduce costs), and to initiate future phases of DH development in Tallaght and elsewhere in South Dublin, it is suggested that a not-for-profit South Dublin District Heating Company is established, which will be owned and controlled by SDCC. This is a similar set-up to Aberdeen Heat and Power, the Aberdeen City Council (ACC) DH company, which coordinates the operations of the Aberdeen DH system on behalf of ACC. This has been a successful model for ACC, allowing it to run the company as a not-for-profit, which reinvests any profit into improving and expanding the services, and lowering heating costs.

This is a typical solution in the early stages of DH market development, where the returns on investment are not commercially attractive. If SDCC is able to take ownership of most of the risks involved in this initial stage of the TDHS project, including investment risk, then it follows suit that it should also take ownership of most of the benefits that accrue from such risks, rather than passing these on to a private sector partner.

Business Model Canvas

The potential business model operated by SDCC in order to deliver the TDHS project has been analysed using the established 'Business Model Canvas' method. The Business Model Canvas is a tool used to visualise all the building blocks of the new DH business and helps to ensure each aspect of the business is being addressed during its planning. The template used is outlined and is explained in Figure 35 on the next page. Each of the nine elements are applied to the TDHS project below:

1. Customer segments

The customers targeted are those buildings that require heat and are located within the Tallaght area, initially prioritising those closest to the energy centre area. The main customers for Phase 1 are SDCC's own buildings – offices, library, theatre, and arts centre. Other nearby customers, such as commercial premises and new developments, have already shown interest in connecting and are planning to connect in Phases 2 and 3. The system is likely to have a mix of commercial, public and residential customers, with public sector customers targeted as 'anchor loads' for the system.

2. Value propositions

The DH system will deliver low-cost, low-carbon heat through a not-for-profit company operated by the local authority. The carbon content is particularly important to public sector buildings as well as businesses with a 'green' agenda. Lower-cost heat is valuable for all customers, particularly for any residential/social housing customers. The not-for-profit element helps to gain customer trust in the project. Customers can also be represented on the SDDH Company board. DH supply also offers the customers a low-cost and 'no hassle' heating system, with little or no maintenance or fuel delivery needs. Other benefits of DH that add value for TDHS customers include no carbon monoxide risks, hot water on demand, no boiler on-site, and increased BERs. There is a distinct value for developers when connecting to the TDHS, as the costs of heating systems are greatly reduced and additional on-site space is created, as well as easily meeting new energy related building regulations.

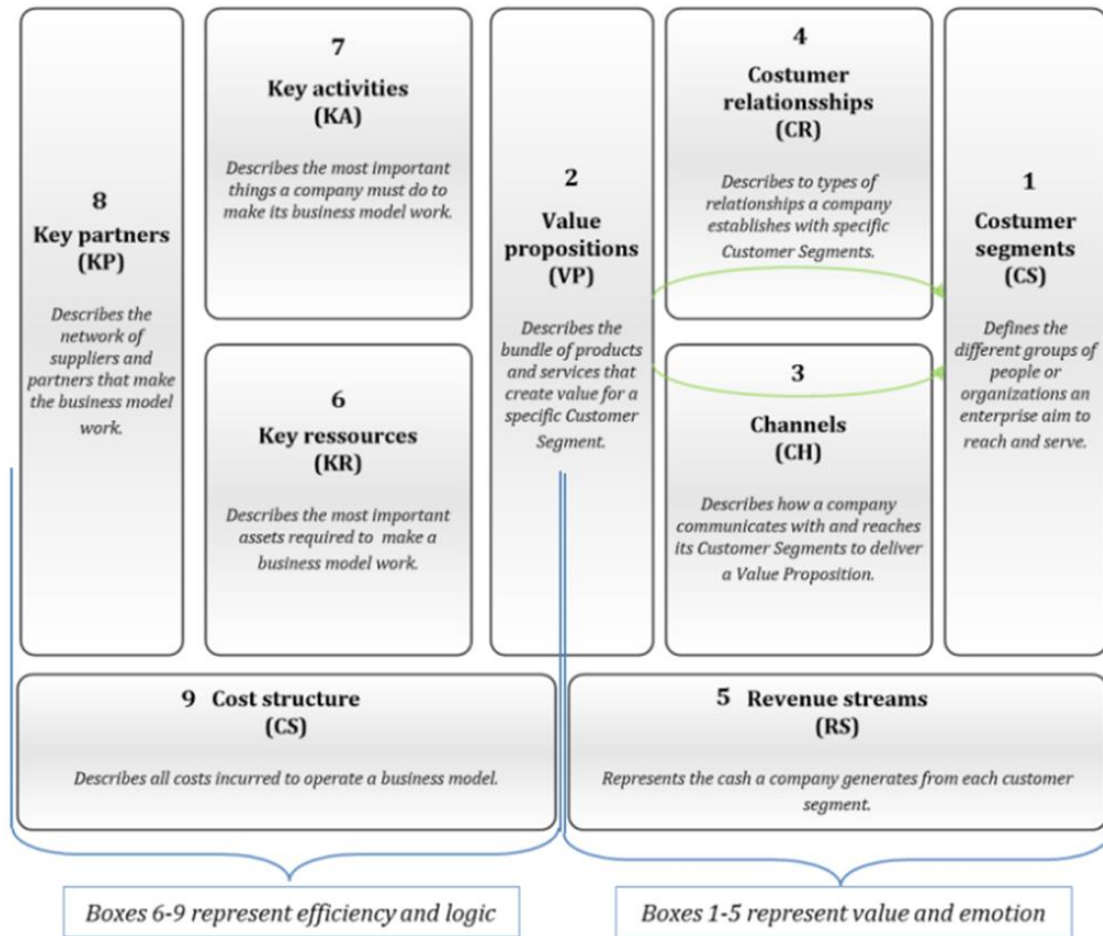

Figure 35: Business Model Canvas Template

3. Channels

The project will be communicated and marketed to customers through the SDDH Project Team. SDCC and Codema will also use their own established channels to advertise the system in the early stages of the project. Additional customers will be identified and targeted through a 'SDDH Heat Plan', and rolled out through marketing and communications channels, including local and national media, large public screens/billboards, social media, leaflets with bills, company website, etc.

4. Customer Relationships

The relationship is between the SDDH Company and the customers. Heat supply contracts with customers that offer access to low-carbon and low-cost heat will be established. These are likely to be long-term contracts to de-risk the project investment.

5. Revenue Streams

Gross revenue is based on sales of heat to customers, which will include a mix of fixed and variable tariff elements. The net revenues are based on gross revenues minus operational costs. These costs will be reduced by optimising the production, sources and storage of heat.

6. Key Resources

The most important assets required to make the business model work are:

- Low-cost/low-carbon heat supply – data centre waste heat
- Customer connections – some already guaranteed by SDCC and additional customers possibly guaranteed through SDCC planning
- Distribution network – SDCC/EU funding covering costs of initial network
- Staff with key expertise – procurement, legal, engineering, marketing and finances

7. Key Activities

The key activity of the SDDH company is the supply of heat that represents value for money to customers. The most important activities that the SDDH company must carry out in order to ensure successful operation are:

- Ensure techno-economic feasibility and effective contracting
- Secure additional customers through marketing and communications
- Ensure satisfactory supply of heat to customers
- Optimise the system operation to lower costs and emissions

8. Key Partners

The key partners, and what they bring to the project, are outlined below:

- SDCC: investment, buildings as secure customers, HeatNet NWE pilot funding, planning powers, local political backing, established local relationships
- Codema: energy contracting, marketing and communications, engineering and energy system planning expertise
- Experienced DH ESCo: heat production/supplier, experience in retail/utilities, experience dealing with energy customers
- Data centre: supply of low-carbon heat at no cost, installation of heat extraction equipment

9. Cost Structure

Costs incurred to operate the business model, the total costs of which need to be kept to below the cost of competitive heat supply:

- Heat price – cost to buy heat from heat suppliers and production fuel costs
- O&M – cost to operate and maintain the network/control centre
- Retail - cost to operate retail element
- Management – cost to operate the TDHS

Elements of the SDDH Company Business Model

Management – The SDDH company will manage all contracting (joint venture, concession, etc.) and procurement of ESCo services (for retail, DBOM, etc.), all investments, all future expansion planning and all communications and marketing. Although these activities are currently carried out by the project team, the staff costs of these services must be covered by company revenues in future.

Voluntary Board/Directors - A board should be established that represents the interests of all stakeholders – customers, investors, suppliers, management, and ESCo, etc.

Retail – The retail element takes care of billing and dealing with customer concerns regarding billing enquiries. This is likely to be contracted to the ESCo or another qualified entity. This is not a major element of the project in Phase 1 due to the low number of customers and connection to SDCC’s own buildings.

Network O&M – This takes care of heat balancing, distribution and storage of heat, and maintaining the heating control equipment and pipelines. There is also an option to also offer maintenance of customer heat exchanger

installations, and recoup costs through standing charges. This element will be part of the proposed DBOM contract, where the contracted entity will also design and build the system.

Heat Production – This element will be delivered by the contracted ESCo and will require a signed agreement with the data centre to guarantee supply. This production needs to be low cost and low-carbon, and consistently optimised to ensure lowest operational costs.

Investor(s) – An investment is required for the pipelines, heat extraction, heat production and storage equipment. The most likely investor identified at this stage is SDCC, with EU grant funding supporting a portion of the investment costs for the network. The structure of the contract procured may also allow part ESCo investment.

10. Procurement and Contracting

10.1 Introduction to Procurement

Procurement is a critical step in the delivery of any DH project. The main functions of the procurement process are:

- To ensure the service providers are sufficiently qualified
- Establish payment terms
- Vet the service providers
- Evaluate and comment on design options
- Negotiate contracts
- Purchase the required goods and services

As part of the HeatNet NWE project, a Procurement Guide³⁷ was developed to provide guidance on how to reach out and access carefully-selected, expert service providers with the required qualifications and expertise to develop good DH projects. This guide can be found on the HeatNet NWE website³⁸.

10.2 Procurement Options for SDCC

There are a number of possible methods of procuring DH contracts for SDCC. Public procurement rules will apply to SDDH Co. for the initial procurement of the ESCo as the company will receive more than 50% of its funding from the public sector. However, this may change in future as the company develops and private sector funding makes a greater contribution (more than 50%). All public sector bodies must follow the fundamental principles of public procurement no matter how large or small the value of the procurement. These principles apply to all public procurement including those below threshold levels. The fundamental principles are: *transparency, integrity, economy, openness, fairness, competition and accountability*.

There are four routes that are potentially suitable for the procurement of the DBOM contract. These include three sections of procurement law that apply in this case, and a Joint Venture option which is governed by company law.

1. S.I. No. 284 of 2016 European Union (award of public authority contracts) Regulations 2016
2. S.I. No. 286 of 2016 European Union (award of contracts by utility undertakings) Regulations 2016
3. S.I. No. 203 of 2017 European Union (award of concession contracts) Regulations 2017
4. Joint Venture

Each Statutory Instrument presents a number of procurement routes that are available to the Contracting Authority (SDCC or SDDH Co.) such as open procedure, restricted procedure, competitive dialogue, etc. The options available under public authority procurement and utilities procurement (options 1 & 2) are very similar except for one key difference - the thresholds above which the rules must be followed are €209,000 for public

³⁷ 4DHC Procurement Guide (2019) http://guidetodistrictheating.eu/wp-content/uploads/2020/04/HeatNet-NWE_DH-Procurement-Guide_District-Heating.pdf

³⁸ <http://guidetodistrictheating.eu/>

authority procurement and €418,000 for utilities procurement. SDDH Co. would be recognised as a utility under this Statutory Instrument.

A concession is where one party concedes to another the right to use an asset to make an economic return. The concessionaire usually pays a percentage of that return to the party offering the concession. The key to the suitability of a concession is the nature of the risk carried by the ESCo. The final option is the Joint Venture. This is governed by company law as a special purpose company is established but the Joint Venture partner must be first procured according to S.I. No. 284 Award of Public Authority Contracts.

Procurements Procedures under S.I. No. 284 (AWARD OF PUBLIC AUTHORITY CONTRACTS)

S.I. No. 284 Award of Public Authority Contracts is the instrument that most commonly applies to procurement in the local authority sector. It has eight procurement procedures that can be selected depending on the complexity of the project. Of these eight procedures only one, *Competitive Dialogue (Art 30)*, is suitable for a contract of this complexity. It is also the only procedure that allows the SDDH project team to procure without first developing a detailed specification for the design and build of the system.

The Competitive Dialogue procedure is a two-stage or restricted procedure. This first involves the pre-qualification process, which results in a shortlist of suitable ESCos. These ESCos are then invited to the Competitive Dialogue interviews to discuss their proposed solutions and to give their feedback on the proposed contract. Once the interview process is complete, a final tender document is prepared and the ESCos tender their final offer. The winning ESCo is then selected based on the evaluation criteria outlined in the tender document.

Table 12: Procurement Procedures Available under S.I. 286 Award of Contracts by Public Authorities

Procedure	Where/When	Suitable option	Why
Open (Art 27)	Large number of suppliers and low value procurement	No	Too basic and restrictive, evaluate mainly based on price
Restricted (Art 28)	More complex tender in a competitive market	No	Too basic and restrictive, evaluate mainly based on price
Negotiated (Art 29)	Where open or restricted has not attracted competition	No	Cannot use open or restricted
Competitive Dialogue (Art 30)	Large complex projects, e.g. PPP, construction	Yes	Allows for award without knowing final value, however, cannot negotiate
Innovation Partnerships (Art 31)	Where needs cannot be met by services/products already on the market	No	Services/products already on the market
Dynamic Purchasing Systems (Art 34)	High volume, repeat purchases	No	Too basic and restrictive, evaluate mainly based on price
Framework Agreements (Art 33)	Repeat needs, e.g. services or supplies	No	Too basic and restrictive, evaluate mainly based on price
Electronic Auctions (Artv35)	Commodity type items e.g. stationery, IT consumables, clearly defined specification	No	Too basic and restrictive, evaluate mainly based on price

Procurements procedures under S.I. No. 286 (AWARD OF CONTRACTS BY UTILITY UNDERTAKINGS)

The utilities directive is broadly similar to S.I. No. 284 Award of Public Authority Contracts but there are some important differences. This would be an option where the SDDH Co. is procuring the contract with the ESCo. In addition to the competitive dialogue procedure this provides a second option, the Negotiated Procedure, with a prior call for competition (Art 46).

The Negotiated Procedure allows public bodies to negotiate directly with suppliers in order to award a contract. The Negotiated Procedure is also a two-stage or restricted procedure. This first involves the pre-qualification process, which results in a short-list of suitable ESCos. These ESCos can then tender their proposed solutions.

The utilities directive also allows for a third option, but it is doubtful if this situation will arise. If no suitable tenders are submitted in response to a procedure with a prior call for competition, then there is the option to go into a direct one-to one negotiation under the *Negotiated procedure without prior call for competition (Art 49)*.

Table 13: Procurement Procedures Available under SI 286 Award of Contracts by Utilities

Procedure	Where/When	Suitable option	Why
Open (Art 44)	Large number of suppliers and low value procurement	No	Too basic and restrictive
Restricted (Art 45)	More complex tender in a competitive market	No	Too basic and restrictive
Negotiated procedure with prior call for competition (Art 46)	Similar process to competitive dialogue, large complex projects, e.g. PPP, Construction	Yes	Allows for award without knowing final value, and can negotiate
Competitive Dialogue (Art 47)	Large complex projects, e.g. PPP, construction	Yes	Allows for award without knowing final value, however cannot negotiate
Innovation Partnerships (Art 48)	Where needs cannot be met by services/products already on the market	No	Services/products already on the market
Negotiated procedure without prior call for competition (Art 49)	Where no suitable tenders have been submitted in response to a procedure with a prior call for competition	Doubtful	Needs to be an emergency situation where swift action is required

Procurements procedures under S.I. No. 203 (AWARD OF CONCESSION CONTRACTS)

A concession is where one party concedes to another the right to use an asset to make an economic return. The concessionaire usually pays a percentage of that return to the party offering the concession. Examples of concession contracts include the operation of a café service in a public building, the operation of public car parks or a toll bridge on a motorway.

The suitability of the concession contract determined by the operation risk. Under S.I. No. 203 (AWARD OF CONCESSION CONTRACTS) paragraph 3(4):

(a) the award of the contract involves the transfer to the concessionaire of an operating risk in exploiting the works or services encompassing demand or supply risk or both; and

(b) the part of the risk transferred to the concessionaire involves real exposure to the vagaries of the market, such that any potential estimated loss incurred by the concessionaire is not merely nominal or negligible.

It further states that the concessionaire (the ESCo) “shall be deemed to assume operating risk where, under normal operating conditions, it is not guaranteed to recoup the investments made or the costs incurred in operating the works or the services which are the subject-matter of the concession contract”.

For the initial contract, in this case the main customers will be SDCC buildings. As SDCC is the contracting authority, it would be difficult to argue that the ESCo would have *real exposure to the vagaries of the market*.

Joint Venture

The final option that is potentially suitable for the procurement of the DBOM contract is the Joint Venture. This, unlike the other three options mentioned, is not governed by procurement law but by company law as it involves the setting up of a special purpose company to develop the system. However, the Joint Venture partner must be selected through a competitive procurement process.

The following is a selection from the HM Treasury publication *Joint Ventures: a guidance note for public sector bodies forming joint ventures with the private sector*³⁹

What is meant by a “joint venture”?

In a Joint Venture each party contributes resources to the venture and a new business is created in which the parties collaborate and share the risks and benefits associated with the venture. A party may provide land, capital, intellectual property, experienced staff, equipment or any other form of asset. Each generally has an expertise or need which is central to the development and success of the new business which they decide to create together. It is also vital that the parties have a ‘shared vision’ about the objectives for the JV.

A JV involves risk sharing; it is suitable where a jointly owned and managed business offers the best structure for the management and mitigation of risk and realisation of benefits whether they involve asset exploitation, improved public sector services or revenue generation. It should not be seen as a delivery model in which the public sector seeks to transfer risk to the private sector through the creation of an arm’s length relationship.

When is a Joint Venture appropriate?

JVs are usually established because the parties have complementary objectives and share a view of the nature and scope of its activities and the JV’s longer-term objectives and benefits. This will need to be tested through the business case development and in most cases through a competitive procurement process. If this alignment of interests is not present, a JV is unlikely to be the best structure to use.

By contrast, if the public sector wishes to conclude arrangements which are clearly defined and limited in scope and with little or no potential for growth and diversification, **or where risk transfer rather than risk sharing** is

³⁹https://assets.publishing.service.gov.uk/government/uploads/system/uploads/attachment_data/file/225321/06_joint_venture_guidance.pdf

sought, the public sector's objectives may be achieved more easily through a more straight forward contractual mechanism or through PFI.

10.3 Example of Procurement Evaluation: Tallaght District Heating Scheme

Possible Procurement Options

The proposed solution for the development of the DH system is for SDCC to invest in and procure a Design, Build, Operate and Maintain (DBOM) contract with an Energy Service Company (ESCO). This is the preferred option as the business model and risk analysis show that SDCC does not have the necessary in-house resources required to design and operate a district heating system. If this work was carried out in-house, it would involve the local authority carrying an unacceptable level of risk. It is suggested that all elements are bundled into one DBOM contract, and therefore one procurement process. Separating the DBOM contracts will involve multiple procurement procedures and add to the delivery timeline. Bundling all elements also allows the ESCo to have more control over the cost of heat supply and allows them to design a system to ensure the lowest costs are achieved. This will allow a competitive process based on the final cost to deliver heat, which will help to guarantee the lowest cost of heat supply for the TDHS system. The procurement process will be guided using Codema's expertise in procurement of energy supply contracts, SDCC's procurement team, existing SEAI supports, and external legal and technical expertise. SDCC may sign a DBOM contract directly with the ESCo, or it could establish an arm's-length, not-for-profit company, the South Dublin District Heating Company (SDDH Co.), which would then enter into a DBOM contract with the ESCo.

Procurement Route Chosen for South Dublin Pilot

There are a number of procurement options as outlined above; the final option will be decided upon by how the project is structured and in particular who carries the risk.

The only direct reference to heat or heat networks is in S.I. No. 203 (award of concession contracts). The suitability of this approach will be determined by the future role that SDCC or the SDDH Co. wish to have in the development of the network. With this approach, the ESCo must carry the full operational risk and have *real exposure to the vagaries of the market*. This approach would limit SDCC's control or influence over the future development of the system.

A joint venture may also be suitable but like the other options, the selection of the JV partner must be properly procured and hence publicly advertised. It is unclear how a boundary would be established under this approach or how the system would be developed in future. Careful consideration of what each party brings to the venture would be critical. As the main aim for SDCC is risk transfer, this option may not be suitable.

The most suitable procurement route is likely to be the 'Competitive Dialogue' (Art. 30) under S.I. No. 284 or the 'Negotiated Procedure', with prior call for competition (Art 46) S.I. No. 286. Both of these options are suitable for a contract of this complexity. They are also the only procedures that will allow the project team to procure without first developing a detailed specification for the design and build of the system. Through the use of this procedure, the technical design risk and the operation risk is transferred to the ESCo, while still giving SDCC full control over the development of the system for this and for all future nodes.

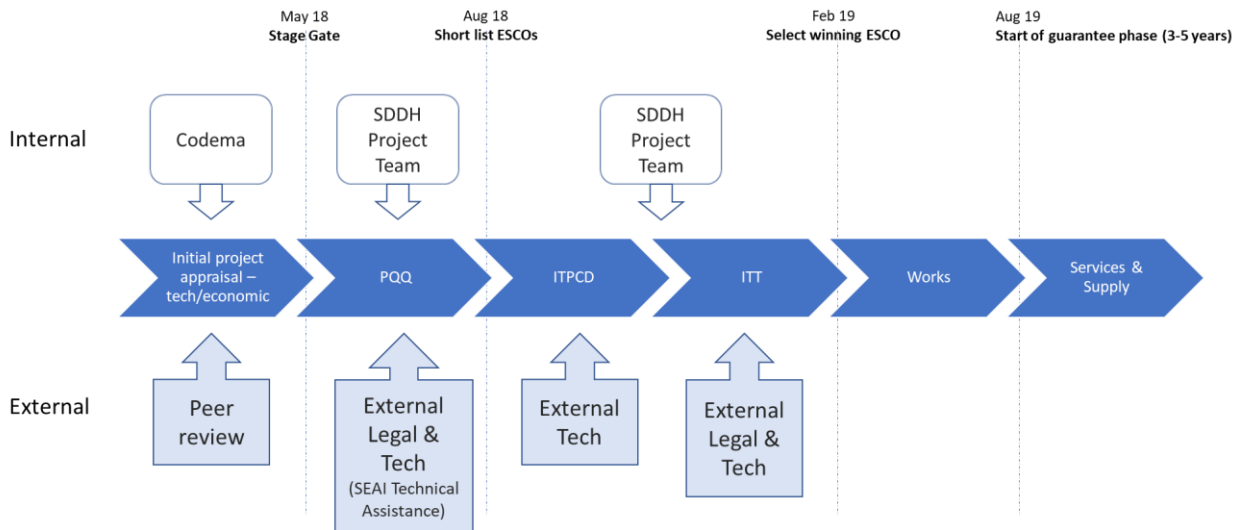

Figure 36: Competitive Dialogue Procurement Timeline

10.4 Example Heat Supply Contract: Proposed Tallaght District Heating Scheme Contract – Local Energy Supply Contract

The contract signed as part of the TDHS DBOM is critical for the overall success and future development of the DH system. The contract will have two distinct phases, the works phase and the operation phase. One potential approach is for SDCC to procure an ESCo to design and build the system for a fixed fee according to a specification defined by SDCC. The same ESCo would then be contracted to operate and maintain the system on behalf of SDCC for a fixed ongoing fee. However, with this traditional approach, SDCC accepts all the risks involved in developing the DH system. If the system does not perform as planned, then SDCC will be faced with the financial burden of correcting this.

An alternative approach, and the preferred option, is to use a Local Energy Supply Contract (LESC). Under an LESL, SDCC or the SDDH Co will buy the heat from the ESCo for a fixed unit cost. How this heat is produced and the risks associated with this production is the responsibility of the ESCo. The ESCo only gets paid if they produce heat. This is similar to how electricity is currently purchased.

Under the National Energy Services Framework, SEAI has developed a template LESL contract - *Local Energy Supply Contract (Full LESL for the design, construction and installation of energy equipment and supply of energy)*. It is proposed that this template contract be used for the development of the DH system.

The LESL is divided into four main sections:

The Works

This section of the contract covers the specification of the design parameters and supplying, installing and commissioning the energy supply equipment, the heat centre, customer heat exchangers and the distribution pipes.

During this phase the ESCo is paid for the works in regular instalments, which will be set out in a schedule to the contract. The contract states (Clause 4) that *the Client shall pay the ESCo the **Works Sum** in such amounts and at such intervals as set out in Schedule 3 or as may otherwise be agreed by the Parties in writing.* The **Works Sum**

includes the cost of design, installation, testing and commissioning of the plant. It does not include the capital cost of the plant as this is addressed through the fixed monthly payment (services payment mechanism).

If SDCC is to pay for all the works (including capital), the contract sets out provisions for a bond: *On or before the Commencement Date the ESCo shall deliver to the Client a performance bond in the form set out in Schedule 8 executed with a surety approved by the Client.*

Where the client is financing the project, it will hold title to the equipment being installed. Where the ESCo is financing the project, the equipment shall remain vested in the ESCo until the termination and expiry of the contract, at which time the client shall have the option to purchase the equipment at its then market value or at a figure to be agreed by the parties negotiating in good faith.

Energy Supply

This section of the contract contains the core provisions of the energy supply agreement. It sets out how the supply is to be connected to the various client facilities and the ESCo's obligation to provide the supply and keep the supply connected to the client's facility. It also sets out the ESCo's obligation to operate and maintain the DH system. The ESCo will be compensated for this service in accordance with the payment mechanism outlined in Section 3 of the contract.

Payment

The payment mechanism allows for the ESCo to be paid on a monthly basis based on the client's actual consumption of energy applied against the agreed supply price. In addition, there is a fixed monthly payment to allow the ESCo to recover its capital expenditure and finance costs.

The monthly payment is to be calculated in accordance with the following formula:

$$\text{Monthly Payment} = (\text{Actual Consumption}) \times (\text{Supply Price}) + [\text{Fixed Monthly Payment}] - \text{Monthly Failed Service Credit}$$

The *Fixed Monthly Payment* provides for the ESCo to recover its cost of finance and capital. This will depend on the ESCo's overall contribution to the capital costs. The *Monthly Failed Service Credit* is a penalty mechanism for the ESCo for not delivering the required amount of heat to a building during a specific period.

The contract also contains provisions for indexation of the agreed supply price(s) and for an annual discount where the ESCo will grant a discount if the client's consumption exceeds a certain agreed threshold amount.

Miscellaneous

The final section of the contract contains many of the standard contractual provisions, such as accommodating value engineering to allow the ESCo to propose the installation of new and improved equipment during the term of the contract and the termination of the agreement, as well as the consequences of such termination and the compensation that will be payable.

Contract Schedules

The schedules include the technical information such as the number of agreed connection points, design documents, specification and standards of performance required from the ESCo, etc.

11. Transition Roadmap

11.1 Actions for Delivering the Transition

This roadmap outlines the short, medium and long-term actions designed to catalyse, promote and deliver district heating projects in South Dublin over a seven-year period. A more detailed roadmap, which expands slightly on the actions below, is provided in Appendix A. These steps will help SDCC to reduce some of the 250,000 tonnes of CO₂ emitted within the County.

Table 14: Transition Roadmap Concise Actions Table

	Short Term		Medium Term			Long Term	
	2019	2020	2021	2022	2023	2024	2025
Planning	Develop a heat map	Use and continual improvement of heat maps	Create zoning areas for DH enabled buildings	Further investigation into the geothermal potential			
	High-level ranking of opportunity areas	Feasibility study for high ranking opportunity area	Funding & procurement for feasible project	Development of new DH network	Re-evaluate opportunity area rankings	Funding & procurement for feasible project	Development of new DH network
	Include identified major growth areas in heat map / transition		Create development plan that looks to co-locate high heat demand with heat sources				
		Consider supplying new buildings from the return of older buildings	In 4DHC zones secure provision of thermal storage				

	Locate new development sites close to heat source	Identify areas suitable for locating energy centres and thermal storage	Create low-temperature 4DHC zoning areas				Investigate opportunities to link existing networks
			Consider opportunities for renewable heat sources				
Pilot - Proof of Concept		Develop TDHS as proof of concept		Extend initial TDHS			
Stakeholder Engagement	Continually engage developers / stakeholders		Highlight the whole energy system benefits				
Legal	Develop suite of legal documents		Update legal documents				
Policy	Continually work with national authorities for the inclusion of DH in applicable building regulations	Encourage high density developments with futureproofed centralised systems					
	Planning policy support for generation and distribution of low-carbon heat						
Technical Guidance		Develop secondary system design guidance to improve connectability					
Capacity Development	Create SDDH Co. - SPV	Develop capacity within SDCC/SDDH Co. to manage the operation of TDHS				Develop capacity within SDCC/SDDH Co. to operate the DH system	

11.2 Next Steps

The actions table outlined on the previous pages gives an overview of the action over the short, medium and long-term. This section discusses the more immediate actions that must be taken to progress the development of DH in South Dublin. These actions are as follows:

- Choose high-ranking opportunity area(s) and develop a feasibility study to determine the suitability for DH
- Continual improvements of the heat map, particularly finding information on industrial waste heat sources that are not part of the EU ETS
- Set up the SDDH Co. special purpose vehicle
- Develop the TDHS network – appoint a contractor, construct the network and energy centre, develop and sign heat supply agreements, etc. Note that the contracts developed can be used as template contracts for future DH projects
- Look at opportunities to further develop planning policy around DH in SDCC, e.g. encourage higher density new developments in identified opportunity areas that include future-proofed centralised heating systems – see Section 3.2 for policy options used in other regions to promote DH
- Development of secondary system design guides / specs in conjunction with the ESCo for the TDHS
- Develop capacity within SDCC/SDDH Co. to manage the operation of TDHS – hire or assign person within SDCC to work in conjunction with the appointed ESCo to manage the TDHS operation (e.g. billing, recording, KPIs, etc.)

Appendix A: Transition Roadmap Actions

	Short Term		Medium Term			Long Term	
	2019	2020	2021	2022	2023	2024	2025
Planning	Develop a heat map that includes heat demand, heat sources and spatial constraints to DH installations to identify opportunity areas	Actively participate in the use and continual improvement of heat maps (demand & source) every two years minimum	Create zoning areas for DH enabled buildings & include safeguarding for future connection	Further investigation into the geothermal potential in the area - this may be based on learnings taken from studies in the Dublin area e.g. the GeoUrban project.			
	High-level ranking of opportunity areas which warrant further investigation	Develop DH feasibility study for high ranking opportunity area (e.g. Clonburris, Grange Castle, Templeogue, Palmerstown, etc.)	Funding & procurement for feasible project	Development of new DH network if found to be feasible	Re-evaluate opportunity area rankings and develop DH feasibility study for a high-ranking area	Funding & procurement for feasible project	Development of new DH network, if found to be feasible
	Include identified major growth areas in transition plan - These areas of new growth will likely be SDZ, Regeneration or new residential areas as shown in the Land Use Zone map		Create development plan that looks to co-locate developments with high heat demand with heat sources - New SDCC County Development Plan due in 2022				

	Short Term		Medium Term			Long Term	
	2019	2020	2021	2022	2023	2024	2025
		Consider supplying newer buildings (that require lower flow temperatures) to the return of older buildings in order to reduce the network return temperatures and improve efficiency	In 4DHC zones secure provision of TS tanks if there is potential to switch to low-carbon sources within the lifetime of a development				
	For locating new development sites, consider proximity to low cost, low-carbon heat source such as an existing DH system	Identify areas suitable for locating EC and TS both within new developments and Council-owned land as the systems grow	Create zoning areas where buildings are to be made compatible with low-temperature supply				Investigate opportunities to link existing networks together
			Consider opportunities for renewable heat sources on brownfield sites for integration with heat networks				
Pilot - Proof of Concept		Develop TDHS as proof of concept		Extend initial TDHS to include identified future loads			

	Short Term		Medium Term			Long Term	
	2019	2020	2021	2022	2023	2024	2025
Stakeholder Engagement	Continually engage developers / stakeholders within opportunity areas (using HeatNet NWE guide to customers for reference)		Highlight the whole energy system benefits of the TDHS operation - grid balancing and renewable energy utilisation				
Legal	Develop energy supply contract (ESC), Heads of Terms and heat supply agreements suitable for DH in South Dublin - can be used as a template for future DH projects. The ESC shall include a mechanism for easy expansion of the network.		Update legal documents to take into account any learnings from the operation of the TDHS				

	Short Term		Medium Term			Long Term	
	2019	2020	2021	2022	2023	2024	2025
Policy	Continually work with national authorities for the inclusion of DH in applicable building regulations	Encourage massing of developments that will lead to higher heat density and promote use of centralised plant future-proofed for connection to DH where network does not already exist. Particularly in RES-N, SDZ and REGEN areas highlighted within the opportunity areas					
	Planning policy support for generation and distribution of low-carbon heat						
Technical Guidance		Develop secondary system design guidance to improve compatibility and to facilitate more efficient operation					
Capacity Development	Create SDDH Co. - SPV responsible for DH in South Dublin	Develop capacity within SDCC/SDDH Co. to manage the operation of TDHS				Develop capacity within SDCC/SDDH Co. to operate the DH system	

Appendix B: Heat Source Map

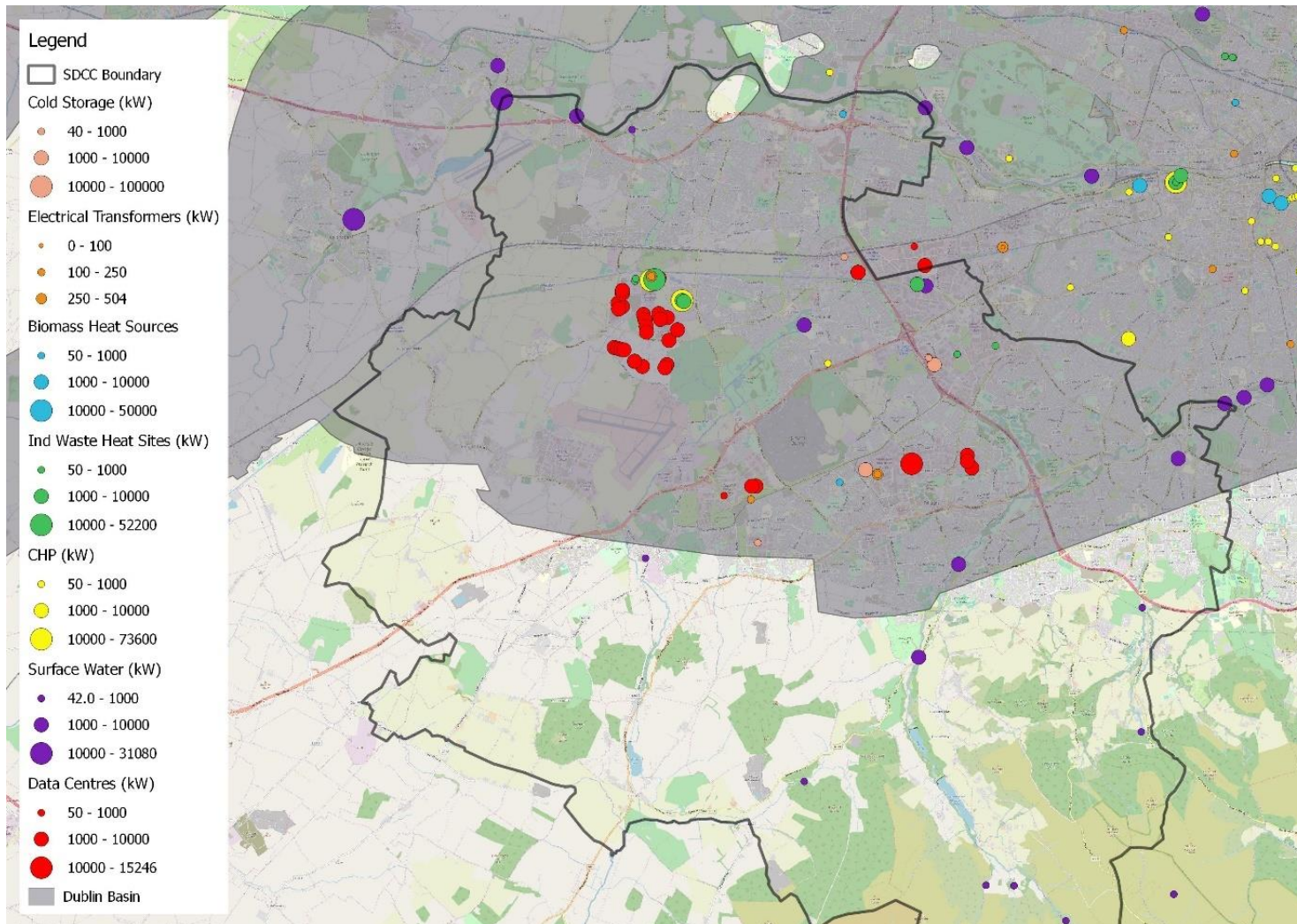

Appendix C: Heat Source Assessment Methodology

This section of the report discusses the approach used in estimating the available capacity of heat from each source and how it is represented on the heat source map.

It should be noted that the heat source capacity is mapped as available heat as opposed to heat delivered to the network to avoid any unfair bias due to assumptions regarding how efficiently this heat might be collected, upgraded, etc.

Table 15: Heat Source Capacity Assessment Methodology

Category	Source	Description
Commercial	Flue gas heat recovery	<p>The flue gas heat recovery was estimated in kilowatts (kW) for large Industrial sites using the flow rate of exhaust gas through the flue, the temperature of the exhaust gas and the minimum temperature at which the gas can be expelled from the flue without causing issues with plumbing or problems with corrosion⁴⁰.</p> <p>The flue gas flow rates were taken from the industrial facilities Industrial Emissions/Integrated Pollution Control licence documentation available from the Environmental Protection Agency. In the cases where this information was superseded by EU ETS data, the verified ETS annual carbon emissions were used to calculate a flue gas flow rate based on the percentage CO₂ by volume⁴¹ and using the relative gas densities at 200°C.</p> <p>Where flue temperatures were stated in the IPC licence, these were used; in the cases where no flue temperature was specified, an average flue temperature for the specific heat technology (e.g. steam boiler, CHP, Thermal Oxidiser etc.) was assumed. These average assumed temperatures were calculated based on the temperatures available in other IPC licence documents. No flue gas temperatures were stated for spark ignition engine CHPs in the IPC licences, hence, exhaust temperature from datasheets were used. Flue gas temperatures for CCGT and Steam Cycle plants were taken from a report on heat recovery steam generators⁴². The assumed minimum flue gas exit temperatures used were chosen to prevent corrosion problems in the flue, based on the fuel being used and to avoid plumbing of the flue gases.</p> <p>When estimating the potential kW of heat recovery based on the annual carbon emission (i.e. from EU ETS data) assumptions on the annual run hours of the heating plant had to be made. Power plants were assumed to have 24/7 operation, apart from two weeks for maintenance work per year. An industrial heating plant was assumed to operate 10 hours per day, seven days per week and assumed 2 weeks of maintenance per year.</p>

⁴⁰ From Energy Management Handbook by Steve Doty & Wayne C. Turner 2009

⁴¹ Tri-reforming of methane: a novel concept for catalytic production of industrially useful synthesis gas with desired H₂/CO ratios by Chunshan Song et al 2004

⁴² <http://www.angelfire.com/md3/vganapathy/hrsgcep.pdf>

		<p>These heat sources are represented on the heat source map as individual point locations. Where possible, these points are located at the known location of the flues within the site itself.</p>
	Industrial process heat recovery	<p>Given the limited information available for specific individual process streams on site, the heat recovery potential for these individual processes could not be assessed. However, one potential low-grade heat source that could be estimated was the capture of waste heat from the sites' sewer water.</p> <p>Where available, the maximum sewer water flow rates (m³ per hour) and maximum sewer water temperatures were taken from the industrial facilities Industrial Emissions/Integrated Pollution Control licence documentation, available from the Environmental Protection Agency. This provided enough information to calculate an estimate of the potential heat extraction from the industrial process waste heat sent to sewer.</p> <p>These heat sources are represented on the heat source map as individual point locations at the point of discharge provided on the EPA licence.</p>
	Commercial / industrial sites with CHP	<p>There are numerous commercial and industrial sites that operate combined heat and power (CHP) plants of various types within the study area, including gas turbine and spark ignition engines. For each CHP plant the thermal capacity was taken from various sources including the plant operator, IPPC licence documents and planning applications.</p> <p>Further details of these units such as the typical operation hours and type of building being supplied has also been provided for some of these units through engagement with operators.</p> <p>These CHP units are represented on the map as individual point locations.</p>
	Commercial / industrial cooling (e.g. data centres, cold storage facilities, hotels, offices)	<p>Certain buildings have significant cooling loads. Cooling is primarily required to provide comfort cooling (i.e. in offices), process cooling, refrigeration and dehumidification. Cooling systems reject heat while in operation. The quantity of heat rejected is dependent on the building cooling load and the cooling systems seasonal efficiency.</p> <p>These cooling system sources are represented on the GIS map as individual point locations.</p>
Infrastructural	Power plant (EfW or other)	<p>The quantity of heat that can be extracted from a power plant depends on its heat-to-power ratio, thermal efficiency and its load profile.</p> <p>There are three different types of power plant included in this study: Combined Cycle Gas Turbine (CCGT), Open Cycle Gas Turbine (OCGT) and Steam Cycle (EfW) plants. Details of the thermal input and electrical generation capacities for each CCGT and OCGT power plant were available online from the ESB⁴³ and EPA websites. Details of the heat-to-power ratio</p>

⁴³ <https://esbarchives.ie/portfolio/>

	<p>and capacity for the EfW facility in Poolbeg were based on figures from similar facilities in Europe.</p> <p>Extracting heat at a usable temperature from EfW and CCGT plants will have an impact on their electricity production. This relationship between electricity production and heat production is represented by the plants z-factor.</p> <p>These heat sources are represented on the heat source map as individual point locations.</p>
Electrical transformers	<p>Electrical transformer sub-stations convert electrical power from one voltage to another. During this process, a certain amount of electrical power is lost and converted into heat. These transformers are often kept cool and insulated by being immersed in insulation oil. The heat contained in this oil can be extracted for use either directly if the temperature is high enough or by passing it through a heat pump depending on the temperature of the oil.</p> <p>The quantity of heat that can be extracted depends on the transformers' efficiency (heat losses), capacity and load factor. The load factor of the transformers is generally in the range of 40% - 60% based on data available on the capacity and loading of high voltage transformers⁴⁴. The efficiency of these transformers was assumed at 99.6% based on discussions with the ESB. The transformer capacity was also taken from the ESB's transformer capacity and load information.</p> <p>The average temperature of the oil was assumed to be 55°C for the assumed load factor; this is based on transformer temperature analysis carried out for similar projects in the UK⁴⁵ and has been deemed comparable by the ESB, to their transformer oil temperatures at this load factor. This heat may be used directly in DH systems that can provide heating at these temperatures. However, in a large proportion of buildings in Ireland, higher supply temperatures will be required, and these can be achieved very efficiently using a heat pump.</p> <p>These transformer heat sources are represented on the heat source map as individual point locations. These locations were provided by ESBI.</p>
Landfill (biogas and waste heat)	<p>The landfill sites identified in South Dublin have been found to contain inert construction and demolition waste. As this waste is inert it does not support the chemical reactions that generate heat or landfill gas. Therefore, these sites have not been included on the map.</p>
WWTW (waste heat, biogas/sludge incineration)	<p>The waste heat capacity estimates are based on annual average temperatures for tertiary tanks of similar waste water treatment sites and the typical flow rate (m³/day) was taken from EPA licence data. The maximum temperature reduction (delta T) of the effluent was assumed based on technical constraints i.e. temperature below which issues with freezing on the evaporator of the heat pump may occur.</p>

⁴⁴ [https://www.esbnetworks.ie/docs/default-source/publications/distribution-hv-substation-transformer-capacity-and-load-information-r0-\(3\).pdf?sfvrsn=2](https://www.esbnetworks.ie/docs/default-source/publications/distribution-hv-substation-transformer-capacity-and-load-information-r0-(3).pdf?sfvrsn=2)

⁴⁵ Management of electricity distribution network losses, Imperial College London & Sohn Associates (2014)

		<p>The potential biogas production was also estimated as a means of assessing suitability for the use of biogas CHP or boilers. This was calculated based on the tonnes of dry solids per annum.</p> <p>These WWTW heat sources are represented on the heat source map as individual point locations. These locations were plotted using the grid reference coordinates stated in the EPA licences.</p>
	Sewage pipes waste heat	<p>The quantity of heat that can be extracted from a sewer depends on the flow and temperature of the sewer water passing through it. Details regarding flow and temperature were taken from EPA licence documents. The maximum temperature reduction (delta T) was assumed based on technical constraints i.e. temperature below which issues with freezing on the evaporator of the heat pump may occur. In cases where the sewer is feeding a waste water treatment works (WWTW) a smaller delta T may be assumed to ensure a high enough temperature is maintained to prevent the biological activity required for treatment of the water from being adversely affected.</p> <p>These sewage pipes heat sources are represented as individual points on the GIS map these locations are based on discharge point coordinates in the EPA licences</p>
Environmental	ASHP	<p>Air-source heat pumps will typically have a lower average efficiency than heat pumps that utilise other sources such as surface water, sewer water, industrial waste heat, ground or geothermal and mine water but benefit from having a readily available heat source. The main technical constraint to the roll out of ASHPs is that with a lower efficiency (particularly during the heating season) they would require greater electrical grid capacity to supply the same heating capacity as heat pumps which utilise other sources.</p>
	Surface water (rivers, lakes, canals)	<p>The kW of extractable heat was estimated using an assumed delta T and the flow rates (95%tile flow) available from the Environmental Protection Agency for water measurement stations that measure water bodies flowing into Dublin. The dry weather flow rates of surface water discharge points from the waste water treatment plant's discharge authorisation documents were also used where available. The 95 percentile and dry weather flows were used for this calculation as the environmental impact of overall river water temperature (as discussed in greater detail further on) was seen as the critical limiting factor. In areas where fisheries are not at risk, it may be more pertinent to use the mean river flow to estimate the heat capacity – this would result in an estimated seven-fold increase in the extractable heat from the river.</p> <p>To reduce the risk of adverse effects on the local fish stocks, a maximum reduction in river water temperature (delta T) due to heat extraction of 2°C was assumed (this figure was chosen as it is between 1.5°C and 3°C, which are the permissible limits on thermal variance set out in the EU Directive⁴⁶ for Salmonid and Cyprinid waters respectively and is also the figure used in similar</p>

⁴⁶ EU Freshwater Fish Directive, 2006

	<p>studies in the UK⁴⁷). It should be noted that not all surface water features are classified as fisheries and in these cases, a larger delta T may be allowed, as these are limited more by technical constraints, i.e. for open loop systems reducing the river water to below 3°C may cause issues with freezing on the evaporator side.</p> <p>River water temperatures were available from integrated water quality assessment reports published by the EPA for the North Western and Neagh Bann, Monaghan and Louth and South East Ireland river basins. These figures were used to get an average river temperature for each month of the year. These average temperatures were used to estimate the seasonal CoP that can be achieved by a proposed heat pump.</p> <p>This heat source is mapped as a point location on the specific water body, which represents the location of where the flow was measured. It can therefore be assumed that at any position along the water body downstream of this point has a heating capacity that at least equivalent to this kW figure.</p>
Seawater	This source was not deemed suitable for the South Dublin region as it is landlocked region.
GSHP	Shallow ground source heat pumps (using horizontal collector or energy piles) are generally more suited to individual building heat supply given the land area requirement for these installations and have not been included in this analysis. Larger closed loop systems are discussed further in the deep geothermal section.
Deep geothermal	<p>The heating capacity from the section of the Dublin Basin which is within the South Dublin boundary was estimated using a software model called DoubletCalc, which has been developed by TNO in the Netherlands. It should be noted that this capacity estimate is based on open-loop system where ground water is extracted through a production well and reinjected back into the ground via an injection well. Closed-loop wells (where a thermally-efficient fluid is circulated within the borehole column) are also suitable for geothermal heating in certain areas but have not been analysed as part of this study. An indication of the suitability of certain areas to different types of geothermal heat supply can be found at http://maps.seai.ie/geothermal/</p> <p>The Dublin Basin contains sedimentary carbonate rock that has a tight matrix (groundmass which consists of tightly compacted material), so the permeability has been assumed to be heavily dependent on fractures and karst. This is somewhat at odds with the DoubletCalc software, which has been developed for homogeneous, isotropic primary porosity media (sandstones). DoubletCalc manual (2014) https://www.nlog.nl/sites/default/files/6ab98fc3-1ca1-4bbe-b0a2-c5a9658a3597_doubletcalc%20v143%20manual.pdf. However, TNO have had</p>

⁴⁷ Water Source Heat Map (DECC, 2014)

some success with using DoubletCalc to predict the output of a doublet in a Dinantian limestone reservoir (Reith, 2018). Data sets in the Dutch study were collected from very similar geological and geothermal conditions to those found in the Dublin Basin, with a median permeability of around 500 mD and a lower median Net to Gross of 55%. Figures taken from TNO report on Californie project:

https://www.rvo.nl/sites/default/files/2017/01/Advies_garantiefonds_aanvraagAARD03001Californie.pdf

Aquifereigenschap	Minimum	Mediaan	Maximum	Eenheid
Permeabiliteit	260	500	6100	mD
Netto/bruto verhouding	0,053	0,055	0,059	/
Bruto dikte van de aquifer	850	900	950	m
Diepte top aquifer (injectieput)	1265	1406	1547	m
Diepte top aquifer (productieput)	1373	1525	1678	m
Saliniteit	40.000	78.000	100.000	ppm

Providence Resources have recently reported average permeabilities of “10s of mD” for a carbonate reservoir in the Porcupine Basin (North-eastern Atlantic Ocean) at depths of 3 km, but with a high Net to Gross of 90%. Based on these real values measured in deep limestone and staying within the normal range of values for hydraulic conductivity in carbonates (Freeze and Cherry, 1979), we have used min, median and max permeability values of 5, 50, and 500 mD respectively (with the aim to be conservative) for the Dublin Basin. We have used a median Net to Gross of 55% based on Dutch capacity models.

It has been assumed that a geothermal gradient of approximately 32°C/km is realistic based on previous temperature measurements in the Dublin Basin (GT Energy Newcastle project, 2008). This would suggest that a heat pump may not be required to supply a DH network at a usable temperature.

Certain assumptions regarding the structure of the wells and reservoir have been made to estimate the heat capacity. These include:

- Reservoir assumed to be 500m thick.
- Top of aquifer assumed to be at 2,000m below sea level.
- Both wells in the doublet are drilled vertically for 1,000m and then deviate at 45 degrees to a final vertical depth of 2,500m.
- At aquifer level, the wells are 1000 m apart to prevent thermal breakthrough.
- Water is re-injected at a temperature of 35°C.

Pump characteristics from Dutch borehole models were adopted for this estimate.

The Dublin Basin is represented as a geographical area (polygon) on the GIS maps. Through our high-level analysis it has been estimated that 28 sets of deep geothermal doublets could be drilled in the South Dublin region. Based on the above assumptions the total capacity of all 28 doublets could range between 86 MW (at 90% probability) and 437 MW (at 10% probability).

The Dublin Basin is represented by a large grey polygon on the GIS map.

	Mine water	There was one mine identified in the South Dublin region but this was not located near any heat demands and therefore was not assessed as part of this exercise.

Appendix D: Heat Source Temperatures & Collection Methods

This appendix gives an indication of the heat source temperatures that may be encountered for each type of heat source prior to upgrading with a heat pump or other heating plant. In some cases, upgrading of the heat to a higher temperature may not be required; this will depend on the required temperature for the network.

Table 16: Indicative Source Temperatures & Heat Collection Methods

Source	Heat Capture Method	Heat Transfer Medium	Typical Source Temp °C	Low-grade / HP required
Commercial				
Flue gas heat recovery	Heat exchanger in flue stack	Flue gas to water	70°C to 250°C	
Industrial process heat recovery	Heat exchanger at appropriate point in the process or at discharge point to sewer where applicable	Water to water <u>or</u> air to water <u>or</u> refrigerant to water	10°C to 250°C	Varies case by case
Industrial sites with CHP	CHP heat offtake from the jacket and flue gas	Water to water	>80°C	
Commercial / industrial cooling (e.g. data centres, cold storage facilities, hotels, offices)	Collector coil / heat exchanger in AHU or cooling system	Refrigerant to water <u>or</u> water to water	15°C to 35°C	Y
Infrastructural				
Power plant (EfW or other)	Heat collected from the condenser. For steam cycles the source temp in fully condensing mode would be much lower (approximately 30°C ⁴⁸). The Z-factor will account for the drop in electricity production due to an increase in heat supply temp in CHP mode.	Water to water	>90°C	
Electrical transformers	Heat exchanger with transformer insulation oil on one side and water on the other	Oil to water	50°C	Y
Landfill gas	Standard heat offtake from boiler or CHP unit used	Combustion	N/A	
Landfill waste heat	Collector coil passing through landfill cells. Collector ideally located in the middle third where the most heat is generated	Water to water <u>or</u> glycol to water	40°C	Y
WWTW waste heat	Heat exchanger / collector located in the tertiary tanks or effluent pipework	Water to water	4°C to 20°C	Y

⁴⁸ 2011 Update of the Technology Map for the SET-Plan: Chapter 7. Cogeneration or Combined Heat and Power

WWTW biogas/sludge incineration	Standard heat offtake from Boiler or CHP unit used	Combustion	N/A	
Sewage pipes waste heat	Heat exchanger / collector located in sewer water flow or built into the pipework itself	Water to water	4°C to 42°C	Y
Environmental				
ASHP	Air blown over evaporator with fan	Air to water	0°C to 20°C (9°C average Dublin)	Y
Surface water (rivers, lakes, canals)	Direct system screens the surface water and passes it over the HP evaporator. Closed loop systems use glycol (or similar) in a collector coil to absorb the heat and transfer it to the HP evaporator.	Water to water	2°C to 26°C	Y
Seawater	Similar to surface water but special consideration should be given to the fact that this is salt water and how this might impact the life and maintenance of certain elements of the system	Water to water	8°C to 16°C	Y
GSHP	Collector coil buried in the soil or incorporated into an energy pile	Water to water <u>or</u> glycol to water	~10°C	Y
Deep geothermal	Heat exchanger with flow from production well and to injection well on one side. To extract the maximum quantity of heat (i.e. reduce reinjection temperature as much as possible) while maintaining a usable supply temperature heat pumps may be utilised.	Water to water <u>or</u> refrigerant to water	> 80°C (@ depth >2.5km) will vary greatly with ground conditions	Varies case by case
Mine water	Similar to surface water can be direct or indirect	Water to water	~10°C	Y

